

TABLE OF CONTENTS

Section 0B	General Information	Section 5	Transmission
		Section 5A	Automatic Transmission
Section 1	Engine	Section 5B	Manual Transmission
Section 1A	Engine General Information	Section 5C	Clutch
Section 1B1	M162 Engine Mechanical	Section 5D1	Part Time - T/C
Section 1B2	M161 Engine Mechanical	Section 5D2	Transfer Case - TOD
Section 1B3	Diesel Engine Mechanical		
Section 1D	Engine Cooling	Section 6	Steering
Section 1E	Engine Electrical	Section 6A	Power Steering
Section 1F1	M162 Engine Controls	Section 6E	Steering Column
Section 1F2	M161 Engine Controls		
Section 1F3	Diesel Engine Controls	Section 7	HVAC (Heating, Ventilation, And Air Conditioning)
Section 1G1	Engine Intake & Exhaust	Section 7A	Heating And ventilation System
		Section 7B	General HVAC (Heating, Ventilation And Air Conditioning) System
Section 2	Suspension	Section 7C	Manual Control Heating, Ventilation And Air Conditioning System
Section 2C	Front Suspension	Section 7D	Automatic Control Heating, Ventilation And Air Conditioning System
Section 2D	Rear Suspension		
Section 2E	Tires And Wheels	Section 8	Restraints
		Section 8A	Seat Belt
Section 3	Drive Line/Axle	Section 8B	Restraints
Section 3A	Front Axle		
Section 3C	Propeller Shaft	Section 9	Body And Accessories
Section 3D	Rear Axle	Section 9A	General Body
		Section 9B	Body Interior
Section 4	Brakes	Section 9C	Body Exterior
Section 4A	Brake System	Section 9D	Body Electrical
Section 4B	Front Brake	Section 9E	Body'S Measuring Dimension
Section 4C	Rear Brake		
Section 4D	Parking Brake		
Section 4E	Antilock Brake System And Traction Control System		

ENGINE

CONTENTS

- SECTION 1A ENGINE GENERAL INFORMATION**
- SECTION 1B1 M162 ENGINE MECHANICAL**
- SECTION 1B2 M161 ENGINE MECHANICAL**
- SECTION 1B3 DIESEL ENGINE MECHANICAL**
- SECTION 1D ENGINE COOLING**
- SECTION 1E ENGINE ELECTRICAL**
- SECTION 1F1 M162 ENGINE CONTROLS**
- SECTION 1F2 M161 ENGINE CONTROLS**
- SECTION 1F3 DIESEL ENGINE CONTROLS**
- SECTION 1G1 ENGINE INTAKE & EXHAUST**

SUSPENSION

CONTENTS

SECTION 2C	FRONT SUSPENSION
SECTION 2D	REAR SUSPENSION
SECTION 2E	TIRES AND WHEELS

DRIVE LINE/AXLE

CONTENTS

SECTION 3A	FRONT AXLE
SECTION 3C	PROPELLER SHAFT
SECTION 3D	REAR AXLE

BRAKES

CONTENTS

SECTION 4A	BRAKE SYSTEM
SECTION 4B	FRONT BRAKE
SECTION 4C	REAR BRAKE
SECTION 4D	PARKING BRAKE
SECTION 4E	ANTILOCK BRAKE SYSTEM AND TRACTION CONTROL SYSTEM

TRANSMISSION

CONTENTS

SECTION 5A AUTOMATIC TRANSMISSION

SECTION 5B MANUAL TRANSMISSION

SECTION 5C CLUTCH

SECTION 5D1 PART TIME - T/C

SECTION 5D2 TRANSFER CASE - TOD

STEERING

CONTENTS

SECTION 6A POWER STEERING

SECTION 6E STEERING COLUMN

HVAC (HEATING, VENTILATION, AND AIR CONDITIONING)

CONTENTS

- SECTION 7A HEATING AND VENTILATION SYSTEM**
- SECTION 7B GENERAL HVAC (HEATING, VENTILATION AND AIR CONDITIONING) SYSTEM**
- SECTION 7C MANUAL CONTROL HEATING, VENTILATION AND AIR CONDITIONING SYSTEM**
- SECTION 7D AUTOMATIC CONTROL HEATING, VENTILATION AND AIR CONDITIONING SYSTEM**

RESTRAINTS

CONTENTS

SECTION 8A SEAT BELT

SECTION 8B RESTRAINTS

BODY AND ACCESSORIES

CONTENTS

SECTION 9A	GENERAL BODY
SECTION 9B	BODY INTERIOR
SECTION 9C	BODY EXTERIOR
SECTION 9D	BODY ELECTRICAL
SECTION 9E	BODY'S MEASURING DIMENSION

SECTION 0B

GENERAL INFORMATION

TABLE OF CONTENTS

Maintenance And Repair	0B-2	At Least Annually	0B-4
Maintenance And Lubrication	0B-2	Standard Bolts Specifications	0B-5
Normal Vehicle Use	0B-2	Basic Specification	0B-6
Explanation Of Scheduled		Dimension	0B-6
Maintenance Services	0B-2	Specifications	0B-7
Owner Inspections And Services	0B-3	Recommended Fluids And Lubricants	0B-9
While Operating the Vehicle	0B-3	Vehicle Identification Number System	0B-10
At Each Fuel Fill	0B-3	Vehicle Identification Number (Vin)	0B-10
At Least Twice a Month	0B-3	ManufacturerS Plate	0B-11
At Least Monthly	0B-3	Engine Number	0B-12
At Least Twice a Year	0B-3	Vehicle Lifting Procedures	0B-14
Each Time The Oil is Changed	0B-4		

MAINTENANCE AND REPAIR

MAINTENANCE AND LUBRICATION

NORMAL VEHICLE USE

The maintenance instructions contained in the maintenance schedule are based on the assumption that the vehicle will be used for the following reasons:

- To carry passengers and cargo within the limitation of the tire inflation pressure. Refer to "Tire and Wheel" in section 2E.
- To be driven on reasonable road surfaces and within legal operating limits.

EXPLANATION OF SCHEDULED MAINTENANCE SERVICES

The services listed in the maintenance schedule are further explained below. When the following maintenance services are performed, make sure all the parts are replaced and all the necessary repairs are done before driving the vehicle. Always use the proper fluid and lubricants.

Engine Oil and Oil Filter Change

Always use above the API SH grade or recommended engine oil.

Engine Oil Viscosity

Engine oil viscosity (thickness) has an effect on fuel economy and cold weather operation. Lower viscosity engine oils can provide better fuel economy and cold weather performance; however, higher temperature weather conditions require higher viscosity engine oils for satisfactory lubrication. Using oils of any viscosity other than those viscosities recommended could result in engine damage.

Cooling System Service

Drain, flush and refill the system with new coolant. Refer to "Recommended Fluids And Lubricants" in this section.

Air Cleaner Element Replacement

Clean the air cleaner element every.

- Gasoline Engine : 15,000 km (10,000 miles)
- Diesel Engine : 10,000 km (6,000 miles)

Replace the air cleaner element every.

- Gasoline Engine : 60,000 km (36,000 miles)
- Diesel Engine : 30,000 km (18,000 miles)

Replace the air cleaner more often under dusty conditions.

Fuel Filter Replacement

Replace the engine fuel filter every.

- Gasoline Engine : 60,000 km (36,000 miles)
- Diesel Engine : 45,000 km (24,000 miles)

Spark Plug Replacement

Replace spark plugs with same type.

- Type : BOSCH : F8DC4
BERU : 14F-8DU4
Champion : C11YCC
- Gap : 0.8 ± 0.1 mm

Spark Plug Wire Replacement

Clean wires and inspect them for burns, cracks or other damage. Check the wire boot fit at the Distributor and at the spark plugs. Replace the wires as needed.

Brake System Service

Check the disc brake pads or the drum brake linings. Check the pad and the lining thickness carefully.

Tire and Wheel Inspection and Rotation

Check the tires for abnormal wear or damage. To equalize wear and obtain maximum tire life, rotate the tires. If irregular or premature wear exists, check the wheel alignment and check for damaged wheels. While the tires and wheels are removed, inspect the brakes.

Tire Rotation (Left-hand Drive Type)

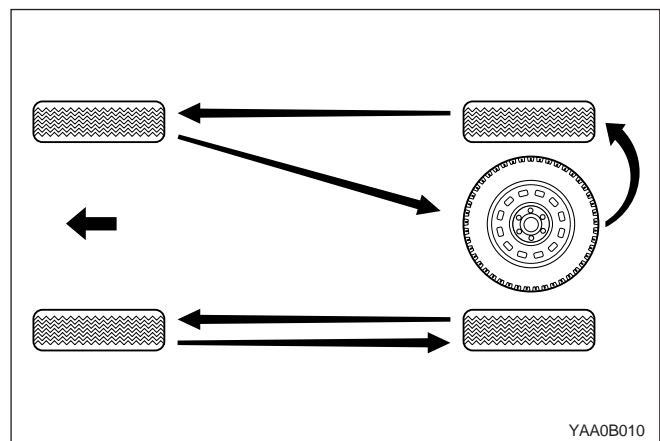

YAA0B010

OWNER INSPECTIONS AND SERVICES

WHILE OPERATING THE VEHICLE

Horn Operation

Blow the horn occasionally to make sure it works. Check all the button locations.

Brake System Operation

Be alert for abnormal sounds, increased brake pedal travel or repeated pulsing to one side when braking. Also, if the brake warning light goes on, or flashes, something may be wrong with part of the brake system.

Exhaust System Operation

Be alert to any changes in the sound of the system or the smell of the fumes. These are signs that the system may be leaking or overheating. Have the system inspected and repaired immediately.

Tires, Wheels and Alignment Operation

Be alert to any vibration of the steering wheel or the seats at normal highway speeds. This may mean a wheel needs to be balanced. Also, a pull right or left on a straight, level road may show the need for a tire pressure adjustment or a wheel alignment.

Steering System Operation

Be alert to changes in the steering action. An inspection is needed when the steering wheel is hard to turn or has too much free play, or is unusual sounds are noticed when turning or parking.

Headlamp Aim

Take note of the light pattern occasionally. Adjust the headlights if the beams seem improperly aimed.

AT EACH FUEL FILL

A fluid loss in any (except windshield washer) system may indicate a problem. Have the system inspected and repaired immediately.

Engine Oil Level

Check the oil level and add oil if necessary. The best time to check the engine oil level is when the oil is warm.

1. After stopping the engine, wait a few minutes for the oil to drain back to the oil pan.
2. Pull out the oil level indicator (dip stick).
3. Wipe it clean, and push the oil level indicator back down all the way.
4. Pull out the oil level indicator and look at the oil level on it.
5. Add oil, if needed, to keep the oil level above the lower mark. Avoid overfilling the engine, since this may cause engine damage.
6. Push the indicator all the way back down into the engine after taking the reading.

If you check the oil level when the oil is cold, do not run the engine first. The cold oil will not drain back to the pan fast enough to give a true oil level reading.

Engine Coolant Level and Condition

Check the coolant level in the coolant reservoir tank and add coolant if necessary. Inspect the coolant. Replace dirty or rusty coolant.

Windshield Washer Fluid Level

Check the washer fluid level in the reservoir. Add fluid if necessary.

AT LEAST TWICE A MONTH

Tire And Wheel Inspection and Pressure Check

Check the tire for abnormal wear or damage. Also check for damaged wheels. Check the tire pressure when the tires are cold (check the spare also, unless it is a stow-away).

Maintain the recommended pressures. Refer to "Tire and Wheel" is in section 0B.

AT LEAST MONTHLY

Lamp Operation

Check the operation of the license plate lamp, the headlamps (including the high beams), the parking lamps, the fog lamps, the taillamp, the brake lamps, the turn signals, the backup lamps and the hazard warning flasher.

Fluid Leak Check

Periodically inspect the surface beneath the vehicle for water, oil, fuel or other fluids, after the vehicle has been parked for a while. Water dripping from the air conditioning system after use is normal. If you notice fuel leaks or fumes, find the cause and correct it at once.

AT LEAST TWICE A YEAR

Power Steering System Reservoir Level

Check the power steering fluid level. Keep the power steering fluid at the proper level. Refer to Section 6A, Power Steering System.

Brake Master Cylinder Reservoir Level

Check the fluid and keep it at the proper level. A low fluid level can indicate worn disc brake pads which may need to be serviced. Check the breather hole in the reservoir cover to be free from dirt and check for an open passage.

Weather-Strip Lubrication

Apply a thin film silicone grease using a clean cloth.

EACH TIME THE OIL IS CHANGED

Brake System Inspection

This inspection should be done when the wheels are removed for rotation. Inspect the lines and the hoses for proper hookup, binding, leaks, cracks, chafing, etc. Inspect the disc brake pads for wear. Inspect the rotors for surface condition. Inspect other brake parts, the parking brake, etc., at the same time. Inspect the brakes more often if habit or conditions result in frequent braking.

Steering, Suspension and Front Drive Axle Boot And Seal Inspection

Inspect the front and rear suspension and the steering system for damaged, loose or missing parts, signs of wear or lack of lubrication. Inspect the power steering line and the hoses for proper hookup, binding, leaks, cracks, chafing, etc. Clean and inspect the drive axle boot and seals for damage, tears or leakage. Replace the seals if necessary.

Exhaust System Inspection

Inspect the complete system (including the catalytic converter if equipped). Inspect the body near the exhaust system. Look for broken, damaged, missing, or out-of-position parts as well as open seams, holes, loose connections, or other conditions which could cause heat buildup in the floor pan or could let exhaust fumes seep into the trunk or passenger compartment.

Throttle Linkage Inspection

Inspect the throttle linkage for interference or binding, damaged, or missing parts. Lubricate all linkage joints and throttle cable joints, the intermediate throttle shaft bearing, the return spring at throttle valve assembly, and the accelerator pedal sliding face with suitable grease. Check the throttle cable for free movements.

Engine Drive Belts

Inspect all belts for cracks, fraying, wear and proper tension. Adjust or replace the belts as needed.

Hood Latch Operation

When opening the hood, note the operation of the secondary latch. It should keep the hood from opening all the way when the primary latch is released. The hood must close firmly.

AT LEAST ANNUALLY

Lap and Shoulder Belts Condition and Operation

Inspect the belt system including: the webbing, the buckles, the latch plates, the retractor, the guide loops and the anchors.

Movable Head Restraint Operation

On vehicles with movable head restraints, the restraints must stay in the desired position.

Spare Tire and Jack Storage

Be alert to rattles in the rear of the vehicle. The spare tire, all the jacking equipment, and the tools must be securely stowed at all times. Oil the jack ratchet or the screw mechanism after each use.

Key Lock Service

Lubricate the key lock cylinder.

Body Lubrication Service

Lubricate all the body door hinges including the hood, the fuel door, the rear compartment hinges and the latches, the glove box and the console doors, and any folding seat hardware.

Underbody Flushing

Flushing the underbody will remove any corrosive materials used for ice and snow removal and dust control. At least every spring clean the underbody. First, loosen the sediment packed in closed areas of the vehicle. Then flush the underbody with plain water.

Engine Cooling System

Inspect the coolant and freeze protection fluid. If the fluid is dirty or rusty, drain, flush and refill the engine cooling system with new coolant. Keep the coolant at the proper mixture in order to ensure proper freeze protection, corrosion protection and engine operating temperature. Inspect the hoses. Replace the cracked, swollen, or deteriorated hoses. Tighten the clamps.

Clean the outside of the radiator and the air conditioning condenser. Wash the filler cap and the neck. Pressure test the cooling system and the cap in order to help ensure proper operation.

STANDARD BOLTS SPECIFICATIONS

Bolt*	Torque (N•m / lb-in)					
	Standard			Limit		
	4T	7T	9T	4T	7T	9T
M3×0.5	0.5 N•m (4.5 lb-in)	0.9 N•m (8 lb-in)	1.3 N•m (12 lb-in)	0.7 N•m (6.3 lb-in)	1.2 N•m (11 lb-in)	17 N•m (15 lb-in)
M4×0.7	1.2 N•m (11 lb-in)	2.0 N•m (18 lb-in)	3.0 N•m (27 lb-in)	1.6 N•m (14 lb-in)	2.6 N•m (23 lb-in)	4.0 N•m (36 lb-in)
M5×0.8	2.4 N•m (22 lb-in)	4.0 N•m (36 lb-in)	5.6 N•m (50 lb-in)	3.1 N•m (28 lb-in)	5.2 N•m (47 lb-in)	7.6 N•m (68 lb-in)
M6×1.0	4.0 N•m (36 lb-in)	6.7 N•m (60 lb-in)	9.7 N•m (87 lb-in)	5.4 N•m (49 lb-in)	9.0 N•m (81 lb-in)	12.7 N•m (114 lb-in)
M8×1.25	8.6 N•m (77 lb-in)	15.7 N•m (12 lb-in)	22.5 N•m (17 lb-in)	12.7 N•m (9 lb-in)	20.6 N•m (15.2 lb-in)	30.4 N•m (22 lb-in)
M10×1.25	18.6 N•m (14 lb-in)	32.3 N•m (24 lb-in)	46.0 N•m (34 lb-in)	25.5 N•m (19 lb-in)	42.1 N•m (31 lb-in)	60.8 N•m (31 lb-in)
M10×1.5	18.6 N•m (14 lb-in)	30.4 N•m (22 lb-in)	44.1 N•m (33 lb-in)	24.5 N•m (18 lb-in)	41.2 N•m (30 lb-in)	58.8 N•m (44 lb-in)
M12×1.25	34.3 N•m (25 lb-in)	56.8 N•m (42 lb-in)	82.3 N•m (61 lb-in)	45.0 N•m (33 lb-in)	75.5 N•m (56 lb-in)	107.8 N•m (80 lb-in)
M12×1.75	32.3 N•m (24 lb-in)	53.9 N•m (40 lb-in)	77.4 N•m (57 lb-in)	43.1 N•m (32 lb-in)	71.5 N•m (53 lb-in)	98.0 N•m (73 lb-in)
M14×1.5	54.0 N•m (40 lb-in)	89.2 N•m (66 lb-in)	127.4 N•m (94 lb-in)	71.6 N•m (53 lb-in)	117.6 N•m (87 lb-in)	166.6 N•m (123 lb-in)
M16×1.5	81.3 N•m (60 lb-in)	107.8 N•m (80 lb-in)	196.0 N•m (145 lb-in)	107.8 N•m (80 lb-in)	186.2 N•m (138 lb-in)	264.6 N•m (196 lb-in)
M18×1.5	117.6 N•m (87 lb-in)	196.0 N•m (145 lb-in)	284.2 N•m (210 lb-in)	156.8 N•m (116 lb-in)	264.6 N•m (196 lb-in)	372.4 N•m (276 lb-in)
M20×1.5	166.6 N•m (123 lb-in)	274.4 N•m (203 lb-in)	392.0 N•m (290 lb-in)	215.6 N•m (160 lb-in)	362.6 N•m (268 lb-in)	519.4 N•m (384 lb-in)
M22×0.5	225.4 N•m (167 lb-in)	372.4 N•m (276 lb-in)	529.2 N•m (392 lb-in)	294.0 N•m (218 lb-in)	490.0 N•m (362 lb-in)	705.6 N•m (522 lb-in)
M24×1.5	284.2 N•m (210 lb-in)	480.2 N•m (355 lb-in)	686.0 N•m (508 lb-in)	382.2 N•m (283 lb-in)	637.0 N•m (471 lb-in)	921.2 N•m (682 lb-in)
M24×2.0	274.4 N•m (203 lb-in)	460.6 N•m (341 lb-in)	666.4 N•m (493 lb-in)	372.4 N•m (276 lb-in)	617.4 N•m (457 lb-in)	891.8 N•m (660 lb-in)

*Diameter X pitch in millimeters

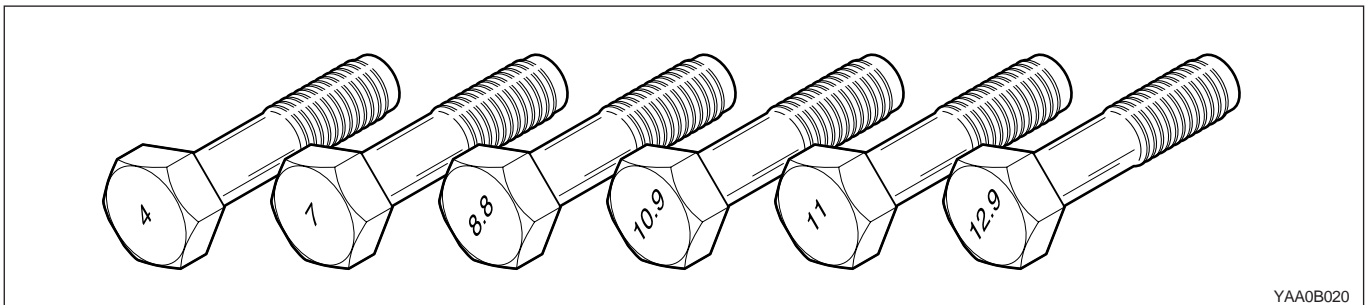

YAA0B020

BASIC SPECIFICATION

DIMENSION

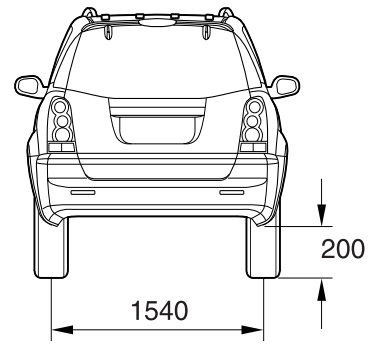
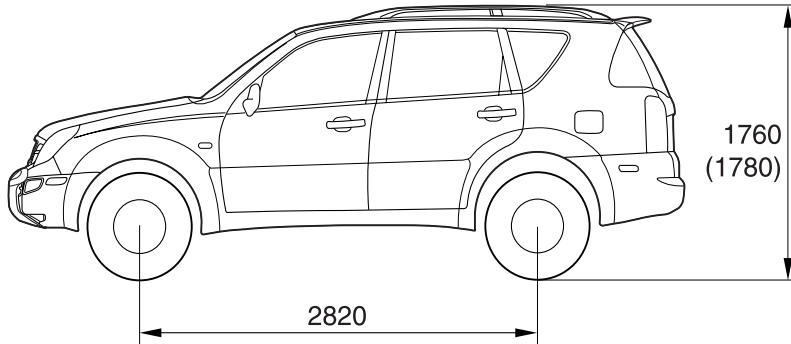
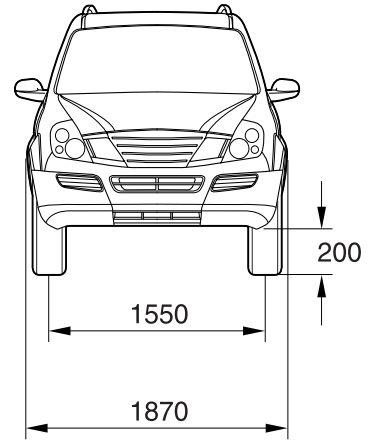
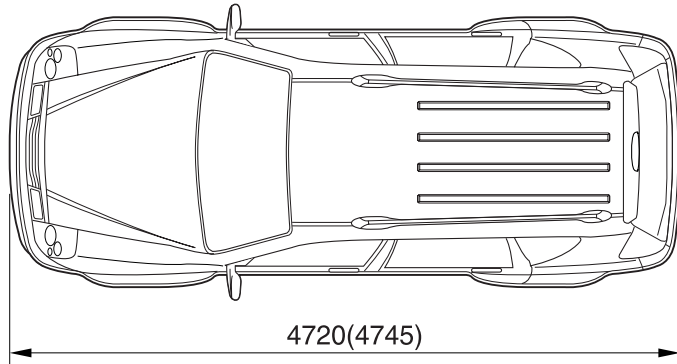

* (): Gasoline engine equipped vehicle

YAA0B030

SPECIFICATIONS

Systems	Items	Diesel	Gasoline G32D (G23D)	
General	Overall length (mm)	4,270	4,745	
	Overall width (mm)	1,870	←	
	Overall height (mm)	1,760	1,780	
	Gross vehicle weight (kg)	AT : 2405, MT : 2365	2415	
	Curb weight (kg)	AT : 1950, MT : 1910	-	
	Min. turning radius (m)	5.6	←	
	Ground clearance (mm)	200	←	
	Fuel	Diesel	Gasoline	
	Fuel tank capacity	80 L	←	
Engine	Model	OM662LA	M162 (M161)	
	No. of cyl./Compression ratio	5 / 22 : 1	6 / 10 : 1	
	Total displacement	2,874 cc	3,199 cc	
	Camshaft arrangement	SOHC	DOHC	
	Max. power	120 ps / 4,000 rpm	220 ps / 6,000 rpm	
	Max. torque	25.5 kg.m / 2,400 rpm	31.9 kg.m / 3,000 rpm	
	Injection timing	BTDC 18° ± 1.0°	BTDC 8°	
	Idle speed	770 ± 50 rpm	770 ± 50 rpm	
	Cooling system	Water-cooled/forced circulation	←	
	Coolant capacity	10.5 L ~ 11 L	11.3 L ~ 11.5 L	
	Lubrication	Gear pump, forced circulation	←	
	Max. oil capacity	8.9 L	9.8 L	
	Turbo charger and cooling type	Turbo charger, air-cooled	-	
Manual transmission	Type	Remote control, floor change type	←	
	Gear ratio	1 st	3.969	←
		2 nd	2.341	←
		3 rd	1.457	←
		4 th	1.000	←
		5 th	0.851	←
		Rev.	3.705	←
Automatic transmission	Model	Electronic	←	
	Type	Floor change type	←	
	Gear ratio	1 st	2.742	←
		2 nd	1.508	←
		3 rd	1.000	←
		4 th	0.708	←
Rev.		2.429	←	

SPECIFICATIONS (Cont'd)

Systems	Items	Diesel	Gasoline G32D (G23D)	
Transference	Model	Part-time	Full-time (Part-Time)	
	Type	Planetary gear type	←	
	Gear ratio	High	1.000 : 1	←
		Low	2.483 : 1	←
Clutch	Type	Hydraulic [A/T: Torque converter]	Torque converter	
	Disc type	Dry single diaphragm type [A/T: 3 elements 1 stage 2 phases]	3 elements 1 stage 2 phases	
Power steering	Type	Rack and pinion	←	
	Steering angle	Inner	36°17'	←
		Outer	32°40'	←
Front axle	Drive shaft type	Ball joint type	←	
	Axle housing type	Build-up type	←	
Rear axle	Drive shaft type	Semi-floating type	←	
	Axle housing type	Build-up type	←	
Brake	Master cylinder type	Tandem type	←	
	Booster type	Vacuum booster	←	
	Type	Front	Disc	←
		Rear	Drum (Disc)	Disc (Drum)
Suspension	Parking brake	Cable type (internal expansion)	←	
	Front	Wishbone + Coil spring	←	
	Rear	5-link + Coil spring	←	
Air conditioner	Refrigerant	R134a	←	
	Compressor type	Vane type	←	
Electrical	Battery type/Capacity (V-AH)	MF / 12 - 90	MF / 112 - 75	
	Starter capacity (V-kW)	12 - 2.2	12 - 1.8	
	Alternator capacity (V-A)	12 - 75 (12 - 90)	12 - 115	

RECOMMENDED FLUIDS AND LUBRICANTS

Usage		Specification	Service interval	Capacity (L)
Engine Oil	D29ST	Approved by MB Sheet 229.1 or 229.3 Viscosity: See MB Sheet 224.1	Initial change: 1,000 km, Change every 10,000 km or 12 months (But, every 5,000 km or 6 months under severe conditions)	6.0 ~ 8.0
	G32D	Approved by MB Sheet 229.1 or 229.3 Viscosity: See MB Sheet 224.1	Initial change: max. 1,000 km, Change every 15,000 km or 12 months (But, every 7,500 km or 6 months under severe conditions)	7.0 ~ 9.0
	G23D			5.5 ~ 7.5
Automatic Transmission Fluid*		CASTROL TQ95	Inspect every 30,000 km or 12 months (But, change every 60,000 km under severe conditions)	Approx. 9.5 L
Manual Transmission Fluid		(ATF DEXRON II or III)	Initially change at 12,000 km, and Inspect every 50,000 km	Approx. 3.4 L
Clutch Fluid (For Manual Transmission)		(DOT 4)	Inspect frequently, Change every 40,000 km or 2 years	As required
Transfer Case Fluid	Part-time	ATF DEXRON [®] II, III, ATF S-2, S-3, S-4, TOTAL FLUID ATX	Inspect every 10,000 ~ 15,000 km Change every 60,000 km	1.2 L
	Full-time	ATF DEXRON [®] II, III, ATF S-2, S-3, S-4, TOTAL FLUID ATX	Inspect every 10,000 ~ 15,000 km Change every 60,000 km	1.4 L
Brake Fluid		DOT4	Change every 40,000 km or 2 years (Inspect frequently)	As required
Front and Rear Axle Fluid	Front Axle	API GL-5 or SAE 80W/90	Inspect frequently Change every 38,000 km	1.4 L
	Rear Axle	API GL-5 or SAE 80W/90	Inspect frequently Change every 38,000 km	1.9 L
Power Steering Fluid		(ATF DEXRON II)	Check and replenish as necessary.	Approx. 1.1 L
Coolant	D29ST	Change every 3 years. And, inspect and replenish as necessary.		10.5~11.0 L
	G23D			10.0~10.5 L
	G32D			11.0~11.5 L
Air Cleaner	Diesel	Clean every 10,000 km, Replace every 30,000 km		
	Gasoline	Clean every 15,000 km, Replace every 60,000 km		
Fuel filter	Diesel	Replace every 45,000 km		
	Gasoline	Replace every 60,000 km		

VEHICLE IDENTIFICATION NUMBER SYSTEM

VEHICLE IDENTIFICATION NUMBER (VIN)

Vehicle Identification Number (VIN) is on the right front axle upper frame.

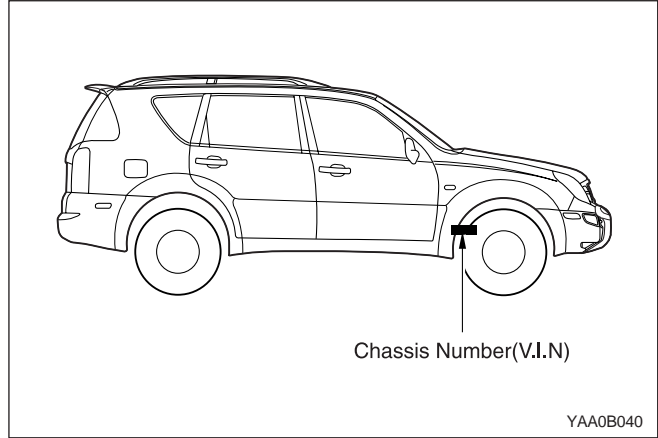

*** K P T G 0 B 1 9 S 1 P 000000**

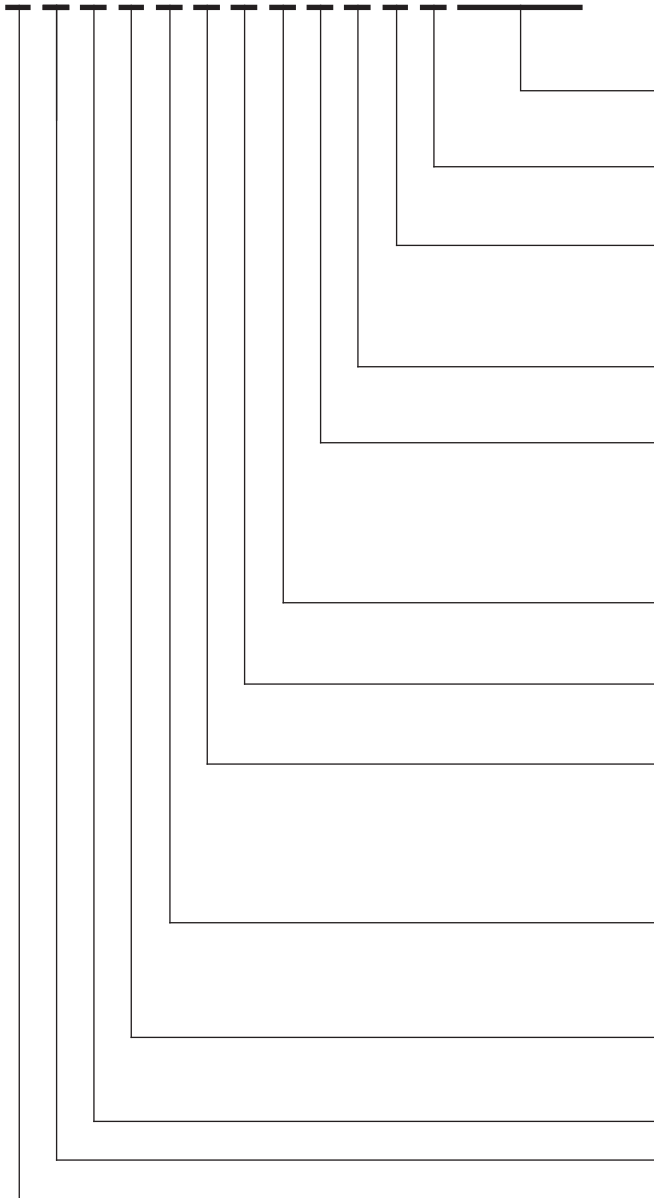

- 12~17. Production Serial Number
: 000001- 999999
- 11. Plant Code
P : PyongTaek Plant
- 10. Model Year
2 : 2002
3 : 2003
- 9. Check Digit
S : All area except North America
- 8. Engine Type
6 : 2295cc, In-line 4Cylinder, Gasoline (E23)
9 : 3199cc, In-line 6Cylinder, Gasoline (E32)
D : 2874cc, In-line 5Cylinder, Diesel (662LA)
- 7. Restraint System
1 : 3-Point Seat Belts, 2 : 2-Point Seat Belts
- 6. Trim Level
A : Standard, B : Deluxe, C : Super Deluxe
- 5. Body Type
0 : 5-Door
1 : 4-Door
2 : 3-Door
- 4. Line Models
G : Rexton (LHD)
H : Rexton (RHD)
- 3. Vehicle Type
T : Passengr Cars, A : Truck
- 2. Maker Identification : P
- 1. Nation : K
- *. Symbol according to No.

MANUFACTURER'S PLATE

- 1 Type Approval No.
- 2 Vehicle Identification No.

 Ssang Yong Motor Company	
1	<input style="width: 80%; height: 20px;" type="text"/>
2	<input style="width: 80%; height: 20px;" type="text"/>
GROSS VEHICLE WEIGHT RATING	<input style="width: 80%; height: 20px;" type="text"/> KG
GROSS VEHICLE WEIGHT TRAILER WITH BRAKE	<input style="width: 80%; height: 20px;" type="text"/> KG
FRONT AXLE MAX WEIGHT RATING	<input style="width: 80%; height: 20px;" type="text"/> KG
REAR AXLE MAX WEIGHT RATING	<input style="width: 80%; height: 20px;" type="text"/> KG
BODY PAINT COLOR	<input style="width: 80%; height: 20px;" type="text"/>

YAA0B050

Manufacturer's Plate Location

Gasoline Engine

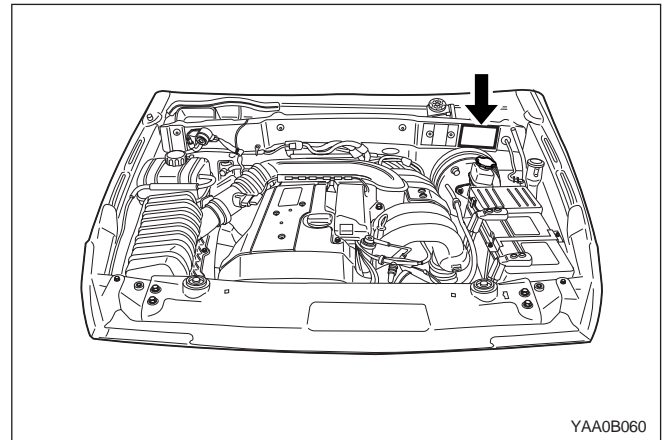

Diesel Engine

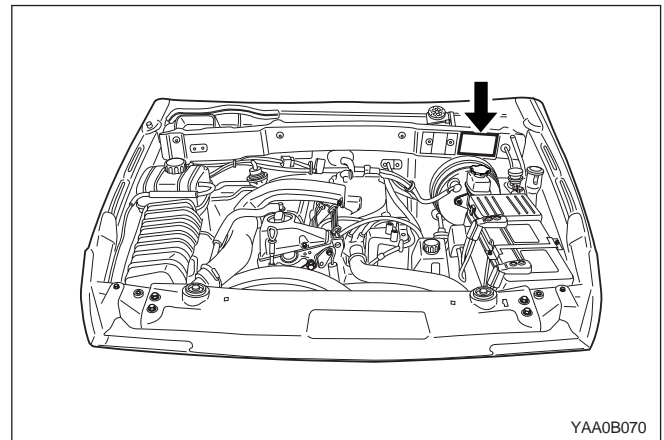

ENGINE NUMBER

Diesel Engine

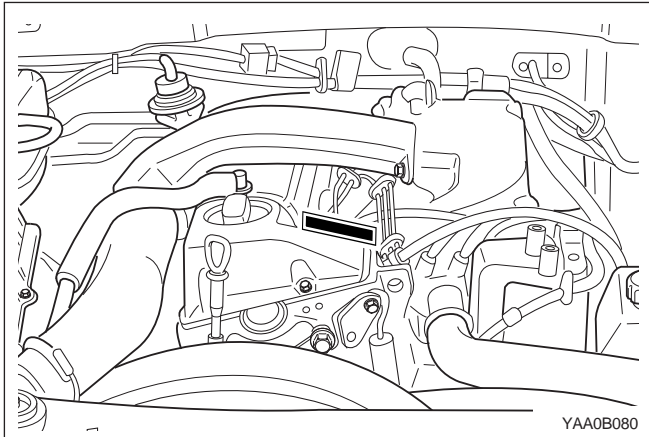

The engine number is stamped on the cylinder block in front of injection pump.

662 920 1 0 012345

Serial Number

0 : Manual T/M
1 : Hydr - Auto Coupling
2 : Automatic T/M

0 : Common
1 : Left - Hand Drive
2 : Right - Hand Drive

5 : REXTON

910 : Non-Intercooler Engine
920 : Intercooler Engine

661 : 2299cc
662 : 2874cc

YAA0B090

Gasolind Engine (3.2L DOHC)

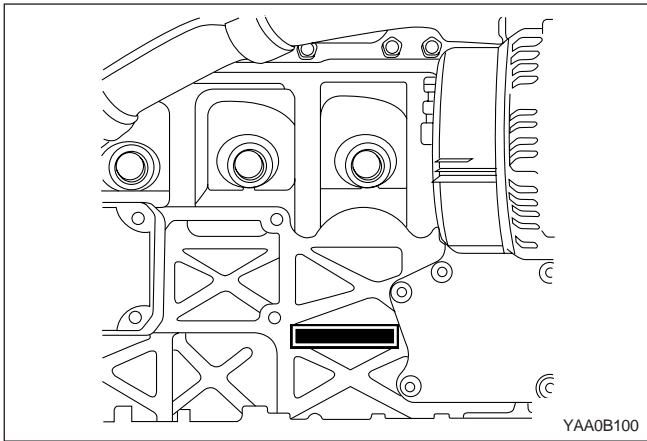

- The engine number is stamped on the lower rear side of the alternator.

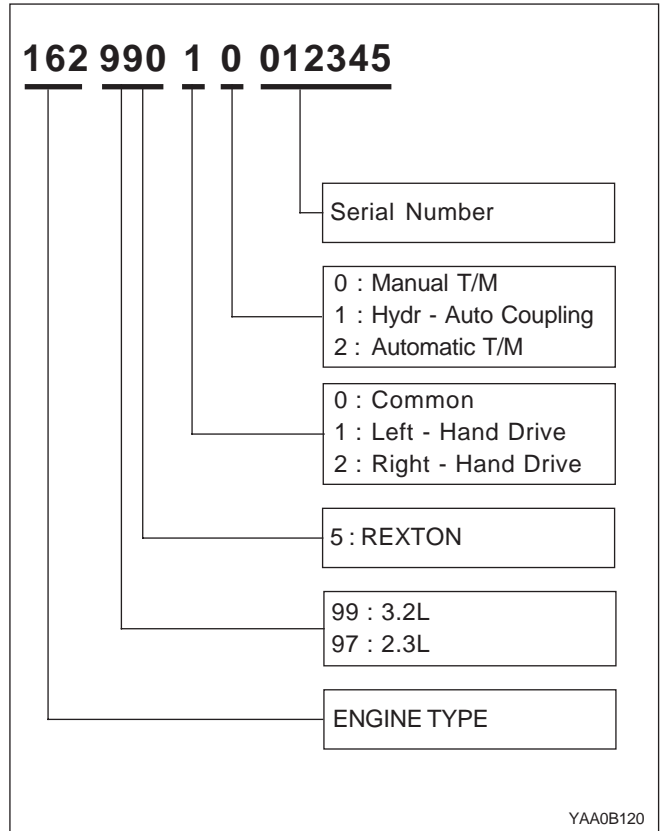

Gasolind Engine (2.3L DOHC)

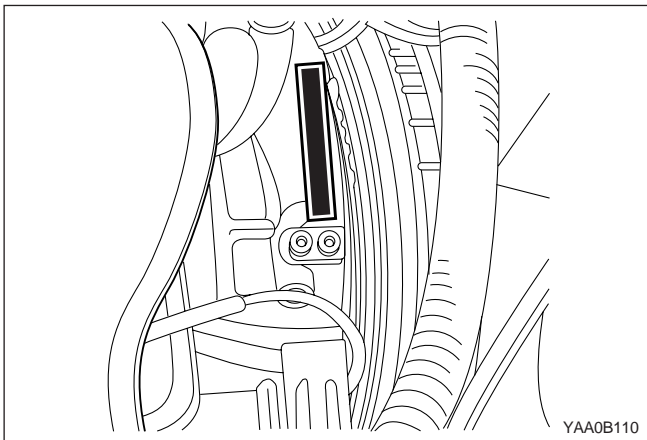

- The engine number is stamped on the upper rear left-hand side of the cylinder block.

VEHICLE LIFTING PROCEDURES

To raise the vehicle, place the lifting equipment only at the points indicated. Failure to use these precise positions may result in permanent vehicle body deformation.

Many dealer service facilities and service stations are equipped with automotive hoists that bear upon some parts of the frame in order to lift the vehicle. If any other hoist method is used, take special care to avoid damaging the fuel tank, the filter neck, the exhaust system, or the underbody.

Using Floor Jack

Front Side

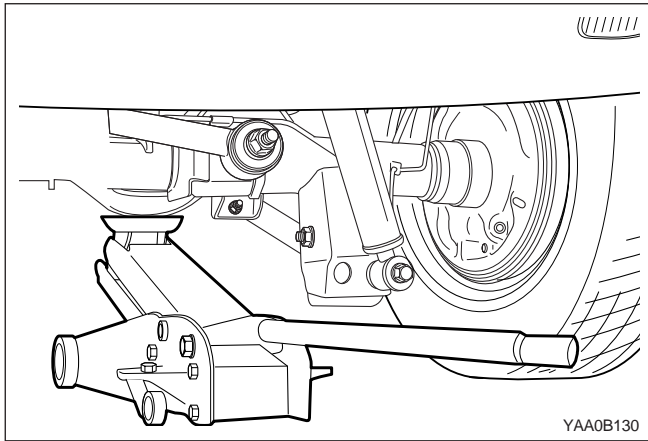

Rear Side

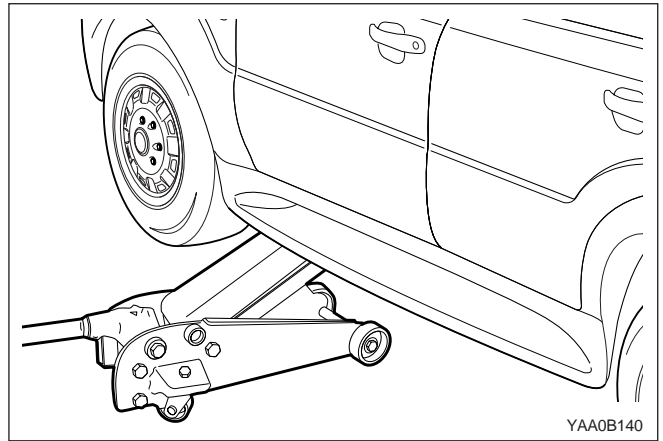

Using Jack

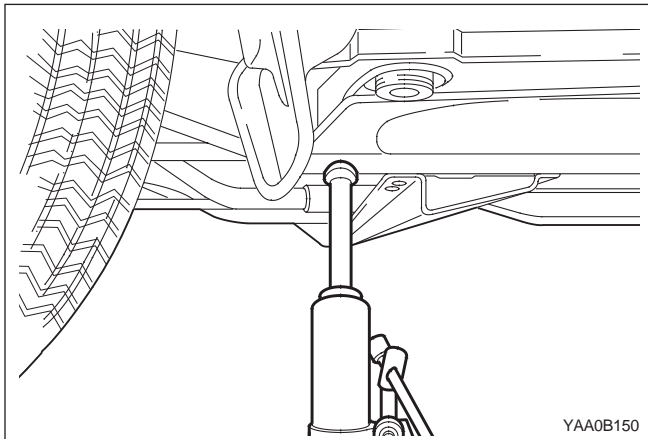

Rearward of Front Tire

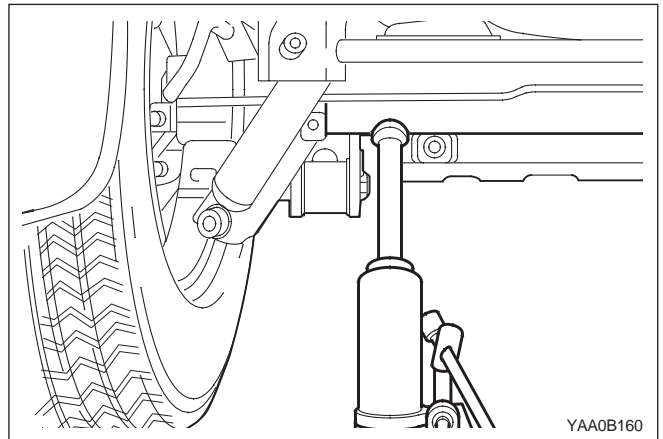

Forward of Rear Tire

SECTION 1

ENGINE

SECTION 1A

ENGINE GENERAL INFORMATION

TABLE OF CONTENTS

Description and Operation	1A-2	Compression Pressure Test (Diesel Engine)	1A-12
Cleanliness and Care	1A-2	Cylinder Pressure Leakage Test (Gasoline Engine)	1A-14
On-Engine Service	1A-2	Cylinder Pressure Leakage Test (Diesel Engine)	1A-16
Component Locator	1A-3	General Diagnosis	1A-18
M162 Engine	1A-3	Specifications	1A-23
M161 Engine	1A-5	Engine Specifications	1A-23
Diesel Engine	1A-7	Performance Curve	1A-24
Diagnostic Information and Procedure	1A-9	Special Tools and Equipment	1A-27
Oil Leak Diagnosis	1A-9	Special Tools Table	1A-27
Compression Pressure Test (Gasoline Engine)	1A-10		

DESCRIPTION AND OPERATION

CLEANLINESS AND CARE

An automobile engine is a combination of many machined, honed, polished and lapped surfaces with tolerances that are measured in the ten-thousandths of an inch. When any internal engine parts are serviced, care and cleanliness are important. A liberal coating of engine oil should be applied to friction areas during assembly, to protect and lubricate the surfaces on initial operation. Proper cleaning and protection of machined surfaces and friction areas is part of the repair procedure. This is considered standard shop practice even if not specifically stated.

Whenever valve train components are removed for service, they should be kept in order. They should be installed in the same locations, and with the same mating surfaces, as when they were removed.

Battery cables should be disconnected before any

major work is performed on the engine. Failure to disconnect cables may result in damage to wire harness or other electrical parts.

ON-ENGINE SERVICE

Caution: *Disconnect the negative battery cable before removing or installing any electrical unit, or when a tool or equipment could easily come in contact with exposed electrical terminals. Disconnecting this cable will help prevent personal injury and damage to the vehicle. The ignition must also be in LOCK unless otherwise noted.*

Notice: Any time the air cleaner is removed, the intake opening should be covered. This will protect against accidental entrance of foreign material, which could follow the intake passage into the cylinder and cause extensive damage when the engine is started.

COMPONENT LOCATOR

M162 ENGINE

Front View

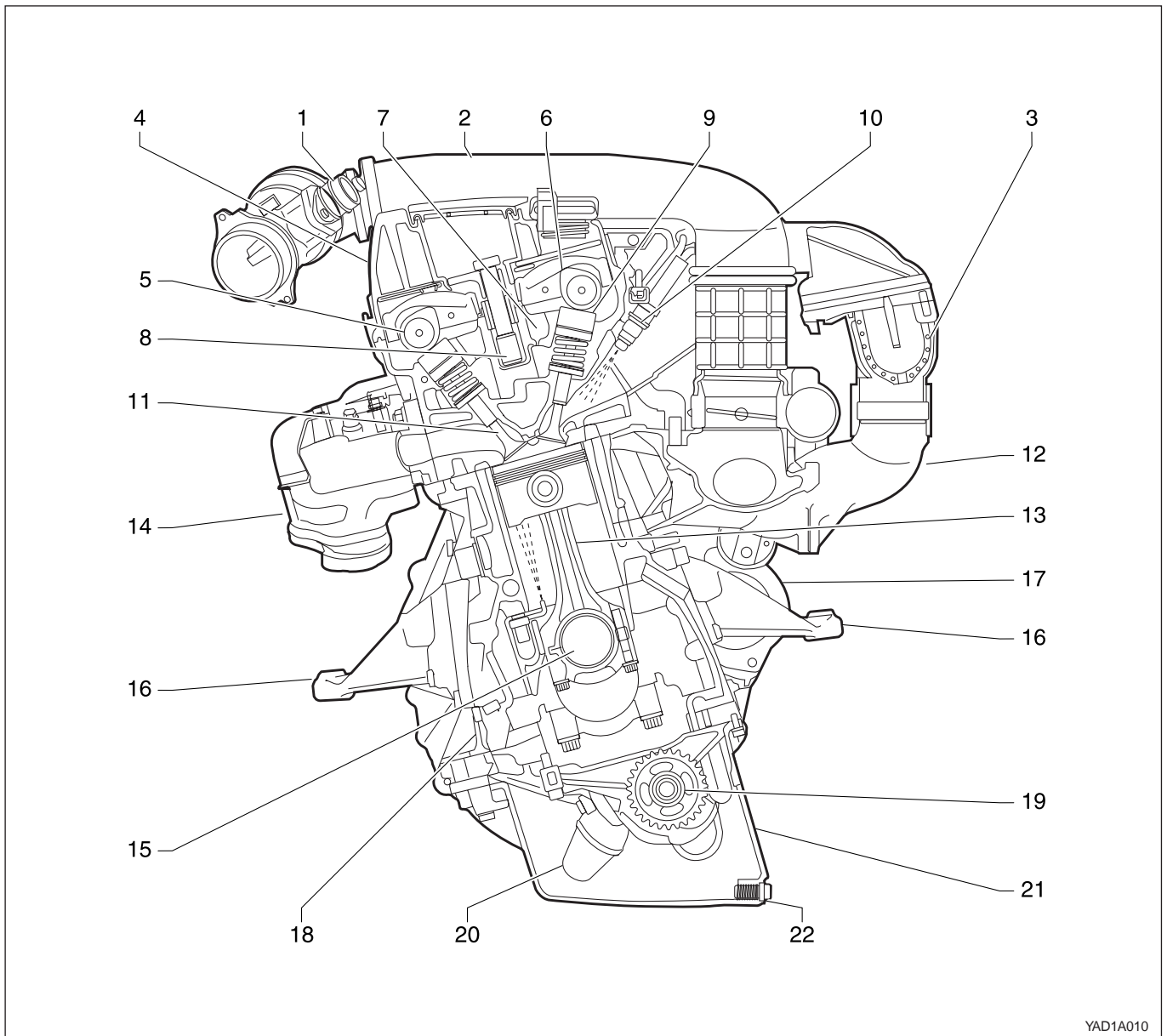

YAD1A010

- | | |
|------------------------|----------------------------|
| 1 HFM Sensor | 12 Intake Manifold |
| 2 Intake Air Duct | 13 Connecting Rod |
| 3 Resonance Flap | 14 Exhaust Manifold |
| 4 Cylinder Head Cover | 15 Crankshaft |
| 5 Exhaust Camshaft | 16 Engine Mounting Bracket |
| 6 Intake Camshaft | 17 Starter |
| 7 Cylinder Head | 18 Crankcase |
| 8 Spark Plug Connector | 19 Oil Pump Sprocket |
| 9 Valve Tappet | 20 Oil Strainer |
| 10 Injector | 21 Oil Pan |
| 11 Exhaust Valve | 22 Drain Plug |

Side View

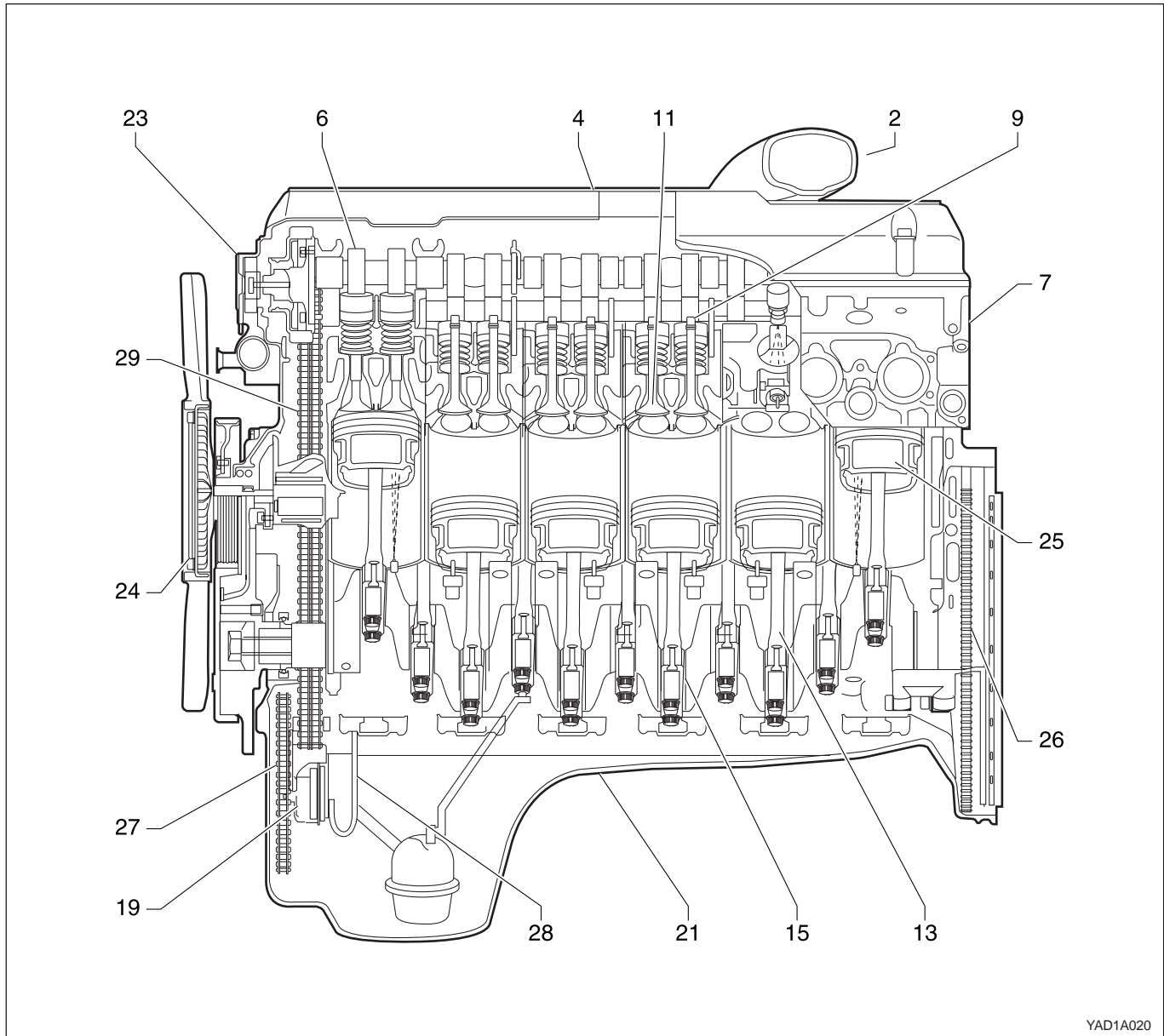

YAD1A020

- 23 Camshaft Adjuster
- 24 Cooling Fan and Viscous Clutch
- 25 Piston
- 26 Flywheel of Drive Plate

- 27 Oil Pump Drive Chain
- 28 Oil Return Pipe
- 29 Timing Chain
- 30 Oil Pump