

# GROUP 33A

# FRONT SUSPENSION

## CONTENTS

<b>GENERAL DESCRIPTION</b> . . . . .	<b>33A-2</b>	DISASSEMBLY AND ASSEMBLY . . . . .	33A-9
		INSPECTION . . . . .	33A-11
<b>FRONT SUSPENSION DIAGNOSIS</b> . . . . .	<b>33A-2</b>	<b>LOWER ARM</b> . . . . .	<b>33A-12</b>
INTRODUCTION TO FRONT SUSPENSION		REMOVAL AND INSTALLATION . . . . .	33A-12
DIAGNOSIS . . . . .	33A-2	INSPECTION . . . . .	33A-13
FRONT SUSPENSION DIAGNOSIS		BALL JOINT DUST COVER	
TROUBLESHOOTING STRATEGY . . . . .	33A-2	REPLACEMENT . . . . .	33A-14
SYMPTOM CHART . . . . .	33A-3	LOWER ARM REAR BUSHING	
SYMPTOM PROCEDURES . . . . .	33A-3	REPLACEMENT . . . . .	33A-14
<b>SPECIAL TOOLS</b> . . . . .	<b>33A-5</b>	<b>STABILIZER BAR*</b> . . . . .	<b>33A-16</b>
<b>ON-VEHICLE SERVICE</b> . . . . .	<b>33A-6</b>	REMOVAL AND INSTALLATION . . . . .	33A-16
FRONT WHEEL ALIGNMENT CHECK AND		INSPECTION . . . . .	33A-18
ADJUSTMENT . . . . .	33A-6	STABILIZER LINK BALL JOINT DUST	
LOWER ARM BALL JOINT END PLAY		COVER REPLACEMENT . . . . .	33A-19
CHECK . . . . .	33A-7	<b>SPECIFICATIONS</b> . . . . .	<b>33A-20</b>
BALL JOINT DUST COVER CHECK . . . . .	33A-8	FASTENER TIGHTENING	
<b>STRUT ASSEMBLY</b> . . . . .	<b>33A-8</b>	SPECIFICATIONS . . . . .	33A-20
REMOVAL AND INSTALLATION . . . . .	33A-8	GENERAL SPECIFICATIONS . . . . .	33A-20
INSPECTION . . . . .	33A-9	SERVICE SPECIFICATIONS . . . . .	33A-20
		LUBRICANT . . . . .	33A-21

### WARNINGS REGARDING SERVICING OF SUPPLEMENTAL RESTRAINT SYSTEM (SRS) EQUIPPED VEHICLES

#### **WARNING**

- *Improper service or maintenance of any component of the SRS, or any SRS-related component, can lead to personal injury or death to service personnel (from inadvertent firing of the air bag) or to the driver and passenger (from rendering the SRS inoperative).*
- *Service or maintenance of any SRS component or SRS-related component must be performed only at an authorized MITSUBISHI dealer.*
- *MITSUBISHI dealer personnel must thoroughly review this manual, and especially its GROUP 52B - Supplemental Restraint System (SRS) before beginning any service or maintenance of any component of the SRS or any SRS-related component.*

#### NOTE

The SRS includes the following components: SRS air bag control unit, SRS warning light, front impact sensors, air bag module, clock spring, and interconnecting wiring. Other SRS-related components (that may have to be removed/installed in connection with SRS service or maintenance) are indicated in the table of contents by an asterisk (\*).

**GENERAL DESCRIPTION**

M1332000100128

The front suspension is a McPherson strut with coil spring. The shock absorber is gas-filled hydraulic double-acting type.

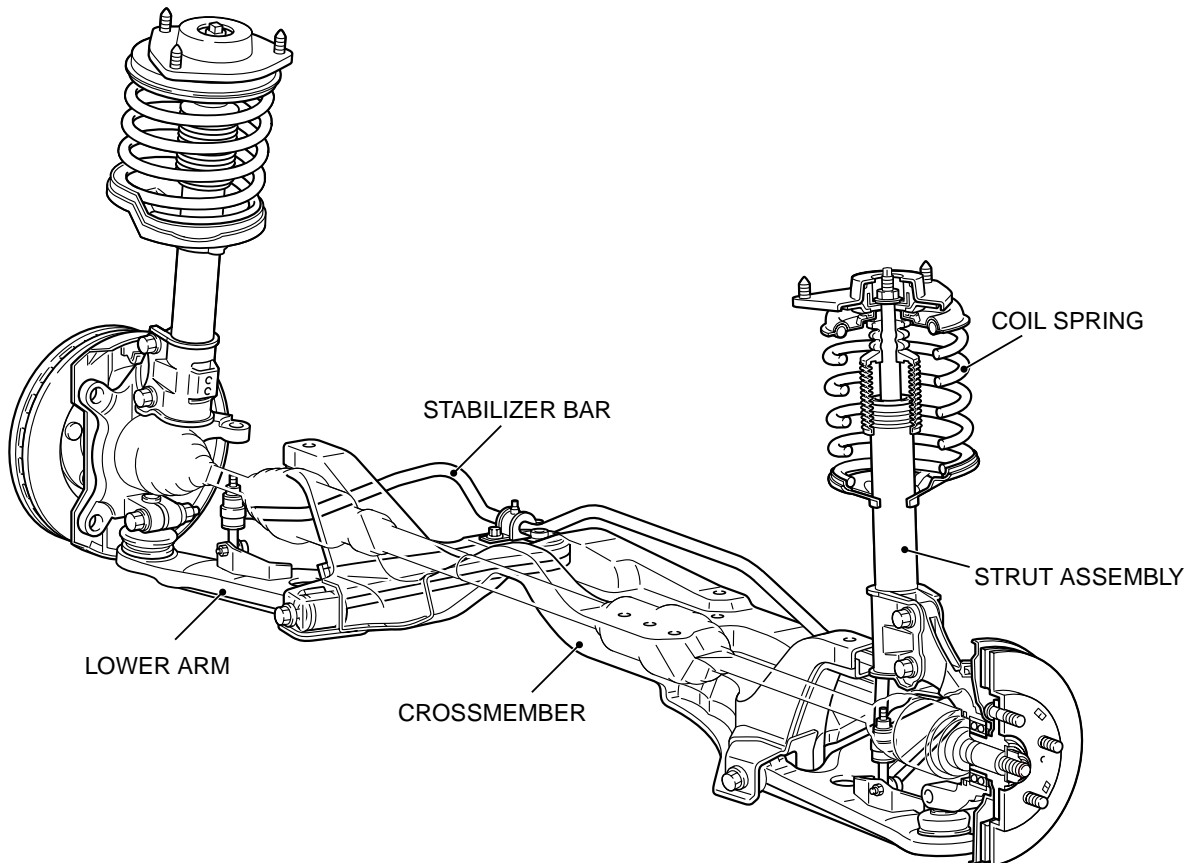
**CONSTRUCTION DIAGRAM**

AC202818 AB

**FRONT SUSPENSION DIAGNOSIS****INTRODUCTION TO FRONT SUSPENSION DIAGNOSIS**

M1332009000162

If the front suspension is faulty, the vehicle will not run straightforward or noise will occur. Incorrect wheel alignment, malfunction of strut assembly, stabilizer bar, coil spring, or worn or out-of-balance tires can cause these problems.

**FRONT SUSPENSION DIAGNOSIS TROUBLESHOOTING STRATEGY**

M1332009100158

Use these steps to plan your diagnostic strategy. If you follow them carefully, you will be sure that you have exhausted most of the possible ways to find a front suspension fault.

1. Gather information from the customer.

2. Verify that the condition described by the customer exists.
3. Find and repair the malfunction by following the Symptom Chart and Symptom Procedures.
4. Verify malfunction is eliminated.

**SYMPTOM CHART**

M1332009400160

SYMPTOM	INSPECTION PROCEDURE	REFERENCE PAGE
Steering wheel is heavy, vibrates or pulls to one side	1	P.33A-3
Excessive body rolling	2	P.33A-3
Poor ride	3	P.33A-4
Unequal ride height	4	P.33A-4
Noise	5	P.33A-4

**SYMPTOM PROCEDURES**

**INSPECTION PROCEDURE 1: Steering Wheel Is Heavy, Vibrates or Pulls to One Side**

**DIAGNOSIS**

**STEP 1. Check the tires.**

Refer to GROUP 31, Diagnosis P.31-2.

**Q: Are the tires in normal condition?**

**YES :** Replace the tires as necessary, then go to Step 2.

**NO :** If out of balance, balance the tires as necessary. If excessively worn, replace the tires as necessary and go to Step 5.

**STEP 2. Check the wheel alignment.**

Refer to P.33A-6.

**Q: Is the wheel alignment correct?**

**YES :** Go to Step 3.

**NO :** Adjust it, then go to Step 5.

**STEP 3. Check the lower arm ball joint.**

**Q: Is the ball joint in good condition?**

**YES :** Go to Step 4.

**NO :** Replace the lower arm assembly, then go to Step 5.

**STEP 4. Check the coil spring.**

**Q: Is the coil spring in good condition?**

**YES :** Go to Step 5.

**NO :** Replace it, then go to Step 5.

**STEP 5. Retest the system.**

**Q: Is the malfunction eliminated?**

**YES :** The procedure is complete.

**NO :** Return to Step 1.

**INSPECTION PROCEDURE 2: Excessive Body Rolling**

**DIAGNOSIS**

**STEP 1. Check for broken or deteriorated stabilizer bar.**

**Q: Is the stabilizer bar in good condition?**

**YES :** Go to Step 2.

**NO :** Replace it, then go to Step 3.

**STEP 2. Check the strut assembly for damage.**

**Q: Is the strut assembly in good condition?**

**YES :** Go to Step 3.

**NO :** Replace it, then go to Step 3.

**STEP 3. Retest the system.**

**Q: Is the malfunction eliminated?**

**YES :** The procedure is complete.

**NO :** Return to Step 1.

**INSPECTION PROCEDURE 3: Poor Ride****DIAGNOSIS****STEP 1. Check for improper tire inflation pressure.**

Refer to GROUP 31, On-vehicle Service – Tire Inflation Pressure Check [P.31-7](#).

**Q: Is the tire inflation correct?**

**YES :** Go to Step 2.

**NO :** Adjust it, then go to Step 4.

**STEP 2. Check for broken or deteriorated coil spring(s).**

**Q: Are the coil spring(s) broken or deteriorated?**

**YES :** Replace the coil spring(s), then go to Step 4.

**NO :** Go to Step 3.

**STEP 3. Check for strut assembly damage.**

**Q: Is the strut assembly damaged?**

**YES :** Replace it, then go to Step 4.

**NO :** Go to Step 4.

**STEP 4. Retest the system.**

**Q: Is the malfunction eliminated?**

**YES :** The procedure is complete.

**NO :** Return to Step 1.

**INSPECTION PROCEDURE 4: Unequal Ride Height****DIAGNOSIS****STEP 1. Check for broken or deteriorated coil spring(s).**

**Q: Is the coil spring(s) broken or deteriorated?**

**YES :** Replace it, then go to Step 2.

**NO :** Go to Step 2.

**STEP 2. Retest the system.**

**Q: Is the malfunction eliminated?**

**YES :** The procedure is complete.

**NO :** Return to Step 1.

**INSPECTION PROCEDURE 5: Noise****DIAGNOSIS****STEP 1. Check for lack of lubrication.**

**Q: Is lubrication inadequate?**

**YES :** Lubricate it, then go to Step 5.

**NO :** Go to Step 2.

**STEP 2. Check the tightened parts for looseness as well as the bushings for wear.**

**Q: Are the tightened parts and bushings in good condition?**

**YES :** Go to Step 3.

**NO :** Replace it, then go to Step 5.

**STEP 3. Check for broken coil spring.**

**Q: Is the coil spring broken?**

**YES :** Replace it, then go to Step 5.

**NO :** Go to Step 4.

**STEP 4. Check for strut assembly damage.**

**Q: Is the strut assembly damaged?**

**YES :** Replace it, then go to Step 5.

**NO :** Go to Step 5.

**STEP 5. Retest the system.**



**Q: Is the malfunction eliminated?**

**YES :** The procedure is complete.

**NO :** Return to Step 1.

**SPECIAL TOOLS**

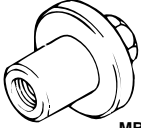
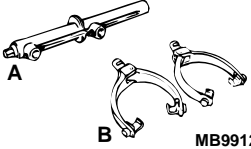
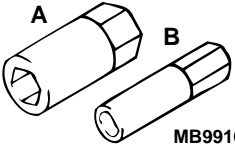
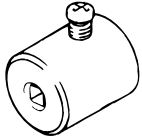
M1332000600156

TOOL	TOOL NUMBER AND NAME	SUPERSESSSION	APPLICATION
 <p>MB991004</p>	<p>MB991004 Wheel alignment gauge attachment</p>	<p>MB991004-01 or General service tool</p>	<p>Wheel alignment measurement</p>
 <p>MB991237</p>	<ul style="list-style-type: none"> <li>• A: MB991237 Spring compressor body</li> <li>• B: MB991238 Arm set</li> </ul>	<p>MIT221369 or general service tool</p>	<p>Front coil spring compression</p>
 <p>MB991680</p>	<p>MB991680 Wrench set</p> <ul style="list-style-type: none"> <li>• A: MB991681 Wrench</li> <li>• B: MB991682 Socket</li> </ul>	<p>—</p>	<p>Strut assembly disassembly and reassembly</p>
 <p>MB991006</p>	<p>MB991006 Preload socket</p>	<p>MB990228-01</p>	<p>Lower arm ball joint breakaway torque check</p>
 <p>MB990800</p>	<p>MB990800 Ball joint dust cover installer</p>	<p>MB990800-01 or General service tool</p>	<p>Lower arm ball joint dust cover installation</p>

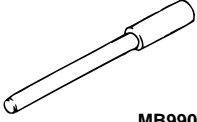
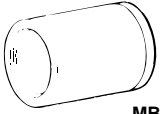
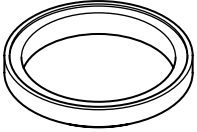
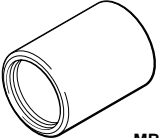
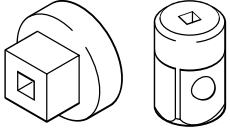
TOOL	TOOL NUMBER AND NAME	SUPERSESION	APPLICATION
 MB990883	MB990883 Rear suspension bushing arbor	MB990883-01 or general service tool	Lower arm bushing removal and press-fitting
 MB990971	MB990958 Rear wheel bearing & installer joint	—	
 MB990887	MB990887 Ring	—	
 MB990890	MB990890 Rear suspension bushing base	MB990890-01 or general service tool	
 MB990326	MB990326 Preload socket	General service tool	

## ON-VEHICLE SERVICE

### FRONT WHEEL ALIGNMENT CHECK AND ADJUSTMENT

M1331000900239

Measure wheel alignment with alignment equipment on a level surface. The front suspension, steering system, wheels, and tires should be serviced to normal condition before measuring wheel alignment.

#### TOE-IN

**Standard value:  $1 \pm 2$  mm ( $0.04 \pm 0.09$  inch)**

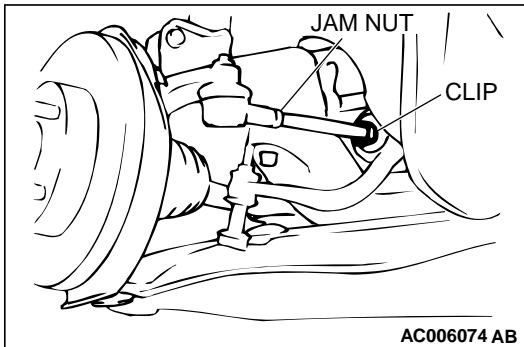

1. Adjust the toe-in by undoing the clip and jam nut, and turning the left and right tie rod turnbuckles by the same amount (in opposite directions).

*NOTE: The toe will move out as the left turnbuckle is turned toward the front of the vehicle and the right turnbuckle is turned toward the rear of the vehicle.*

2. Install the clip and tighten the jam nut to the specified torque.

**Tightening torque:  $52 \pm 2 \text{ N}\cdot\text{m}$  ( $38 \pm 2 \text{ ft}\cdot\text{lb}$ )**

3. Confirm that the toe-in is at the standard value.
4. Use a turning radius gauge to check that the steering angle is at the standard value.

#### STEERING ANGLE

**Standard value:**

**$34^\circ 50' \pm 1^\circ 30'$  <Inner wheel>**

**$29^\circ 20'$  <Outer wheel (reference)>**

#### CAMBER, CASTER AND KINGPIN INCLINATION

**Required Special Tool:**

- MB991004: Wheel Alignment Gauge Attachment  
<Vehicles with aluminum wheels>

**Standard value:**

**Camber  $0^\circ 00' \pm 30'$  (Left/right deviation within  $30'$ )**

**Caster  $3^\circ 10' \pm 30'$  (Left/right deviation within  $30'$ )**

**Kingpin inclination  $12^\circ 05' \pm 1^\circ 30'$**

*NOTE: Camber and caster are preset at the factory and cannot be adjusted.*

#### CAUTION

**Never subject the wheel bearings to the vehicle load when the drive shaft nuts are loosened.**

*NOTE: For vehicles with aluminum type wheels, attach the camber/caster/kingpin gauge to the driveshaft by using the special tool MB991004. Tighten the special tool MB991004 to the same torque  $245 \pm 29 \text{ N}\cdot\text{m}$  ( $181 \pm 21 \text{ ft}\cdot\text{lb}$ ) as the driveshaft nut.*

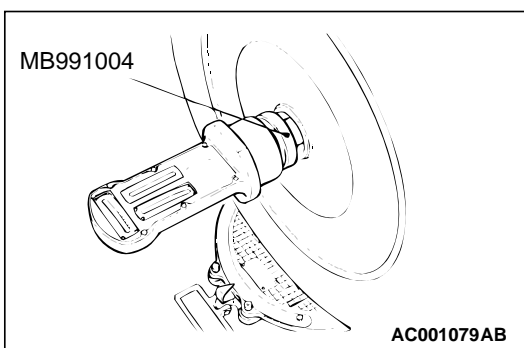

#### LOWER ARM BALL JOINT END PLAY CHECK

M1332011300018

1. Raise the vehicle.
2. Remove the stabilizer link from the lower arm.
3. Move the lower arm up and down with your hands to check for an excessive play in the axial direction of the ball joint. If there is an excessive play, replace the lower arm assembly.

## BALL JOINT DUST COVER CHECK

M1332008600183

1. Press the dust cover with your finger to check that there are no cracks or damage in the dust cover.
2. If the dust cover is cracked or damaged, replace the lower arm assembly.

*NOTE: If the dust cover is cracked or damaged, it is possible that there may also be damage to the ball joint.*

## STRUT ASSEMBLY

## REMOVAL AND INSTALLATION

M1332001100143

**CAUTION**

For vehicles with ABS, be careful when handling the pole piece at the tip of the speed sensor so as not to damage it by striking against other parts.

**Pre-removal Operation**

- Washer Tank Assembly Removal (Refer to GROUP 51, Windshield Wiper and Washer P.51-23.) <Pre-removal of the strut assembly (RH)>

**Post-installation Operation**

- Washer Tank Assembly Installation (Refer to GROUP 51, Windshield Wiper and Washer P.51-23.) <Post-installation of the strut assembly (RH)>
- Front Wheel Alignment Adjustment (Refer to P.33A-6.)

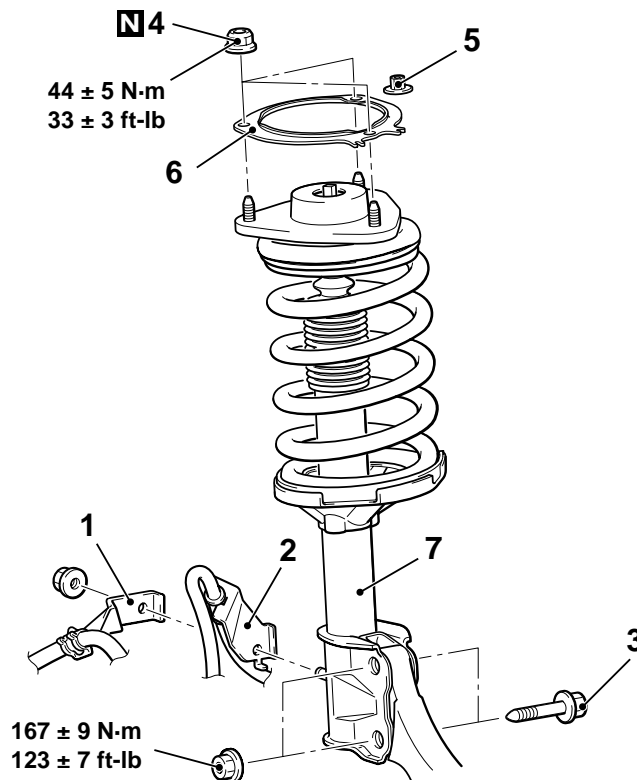

AC202820AB

**REMOVAL STEPS**

1. FRONT ABS SENSOR HARNESS BRACKET <VEHICLES WITH ABS>
2. BRAKE HOSE BRACKET
3. KNUCKLE CONNECTION

**REMOVAL STEPS (Continued)**

4. STRUT MOUNTING NUT
5. INSULATOR CLIP
6. STIFFENER PLATE
7. STRUT ASSEMBLY



INSPECTION

M1332001200140

- Check for oil leaks from the strut assembly.
- Check the strut assembly for damage or deformation.

DISASSEMBLY AND ASSEMBLY

M1332001300147

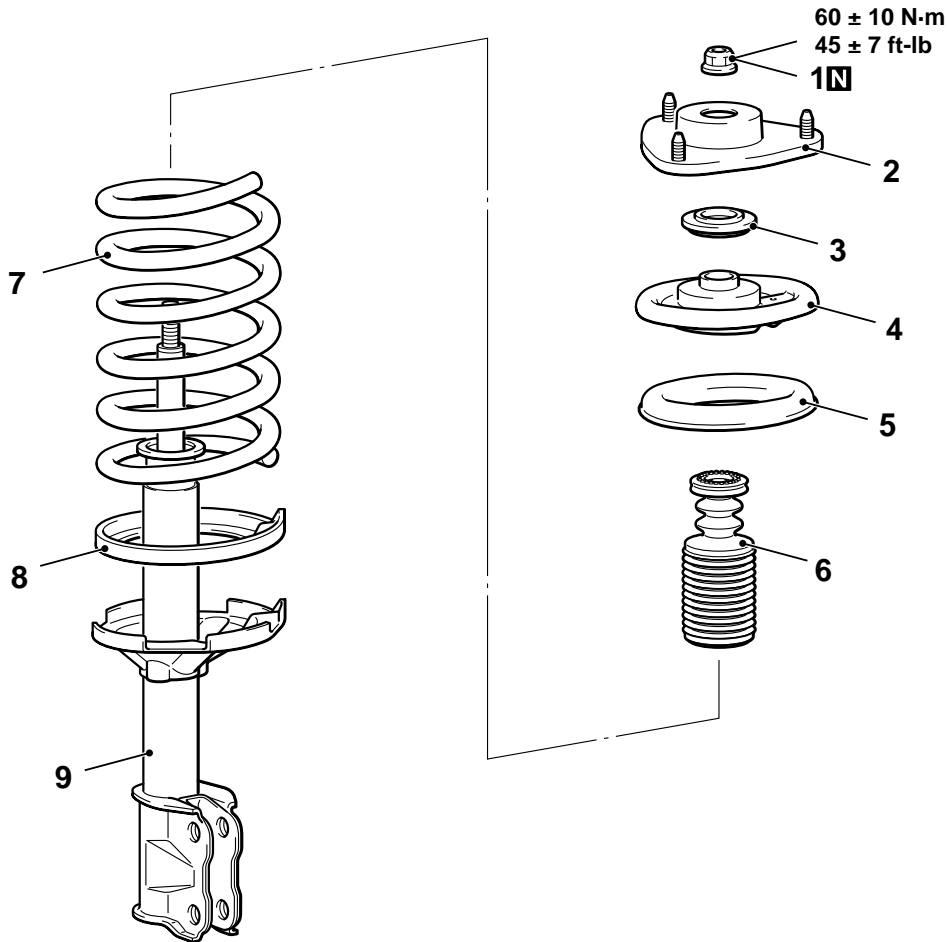

AC101427AD

- <<A>> >>A<<
- DISASSEMBLY STEPS**
1. SELF-LOCKING NUT
  2. STRUT INSULATOR ASSEMBLY
  3. BEARING
  4. UPPER SPRING SEAT
  5. UPPER SPRING PAD
  6. BUMP RUBBER
  7. COIL SPRING

- DISASSEMBLY STEPS (Continued)**
8. LOWER SPRING PAD
  9. STRUT ASSEMBLY

**Required Special Tools:**

- MB991237: Spring Compressor
- MB991238: Arm Set
- MB991680: Wrench set

## DISASSEMBLY SERVICE POINTS

## &lt;&lt;A&gt;&gt; SELF-LOCKING NUT REMOVAL

**⚠ CAUTION**

- Install the special tools evenly, and so that the maximum length will be attained within the installation range.
- Do not use an impact wrench to tighten the bolt of the special tool MB991237, otherwise the special tool will break.

1. Use the special tools MB991237 and MB991238 to compress the coil spring.

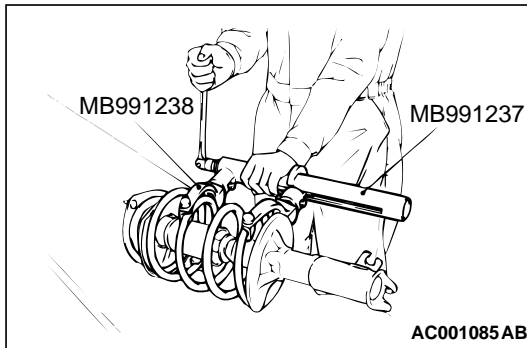
**⚠ WARNING**

**Do not use an impact wrench to remove the self-locking nut. Vibration of the impact wrench will cause the special tools MB991237 and MB991239 to slip and cause personal injury.**

2. Use the special tools MB991681 and MB991682 to secure the strut, and then remove the self-locking nut.

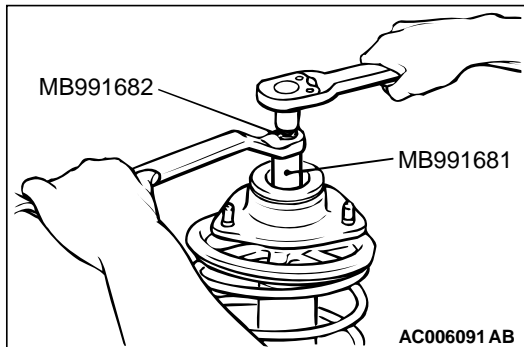

## &lt;&lt;B&gt;&gt; STRUT ASSEMBLY REMOVAL

**⚠ WARNING**

**Wear goggles when drilling to protect your eyes from flying metal debris.**

The gas must be discharged from the strut assembly before discarding it. Place the assembly horizontally with its piston rod extended. Then drill a hole of approximately 3 mm (0.1 inch) in diameter at the location shown in the illustration and discharge the gas.

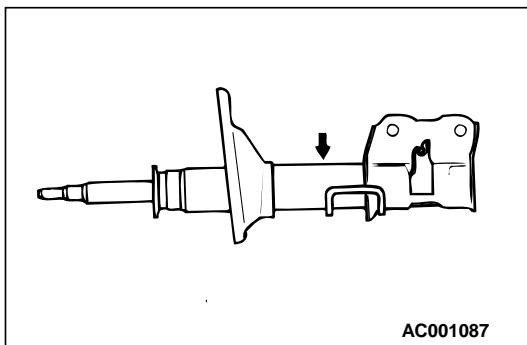

## ASSEMBLY SERVICE POINT

### >>A<< SELF-LOCKING NUT INSTALLATION

1. Ensure that the bearing is seated correctly.

#### CAUTION

**Do not use an impact wrench to tighten the bolt of special tool MB991237, otherwise the special tool will break.**

2. Install the special tools MB991237 and MB991238 to the strut assembly same as its removal.
3. While the coil spring is being compressed by the special tools, temporarily tighten the self-locking nut.

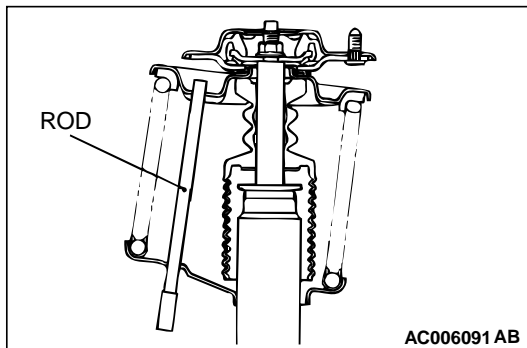
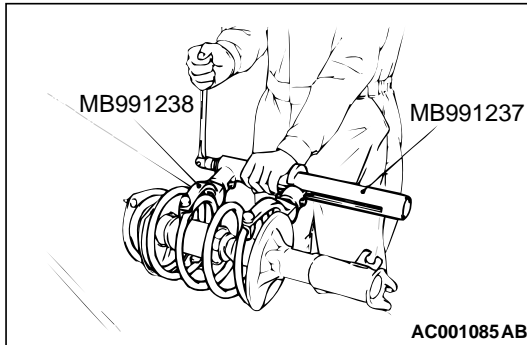

4. Align the hole in the strut assembly lower spring seat with the hole in the upper spring seat.

*NOTE: Using a rod as shown facilitates the alignment.*

5. Align both ends of the coil spring with the grooves in the spring seat, and then loosen the special tools.

#### CAUTION

**Do not use an impact wrench to tighten the self-locking nut, otherwise the self-locking nut will be damaged.**

6. Using the special tools MB991681 and MB991682, tighten the self-locking nut to  $60 \pm 10$  N·m ( $45 \pm 7$  ft·lb).

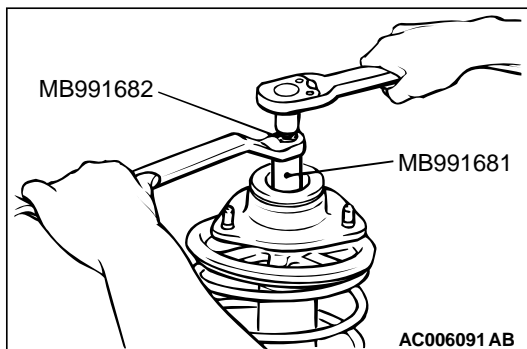

## INSPECTION

M1332001400100

- Check the bearing for wear or rust.
- Check the rubber parts for damage or deterioration.
- Check the spring for deformation, deterioration or damage.
- Check the shock absorber for deformation.

# LOWER ARM

## REMOVAL AND INSTALLATION

M1332001600159

**CAUTION**

\* : Indicates parts which should be temporarily tightened, and then fully tightened with the vehicle on the ground in an unladen condition.

**Post-installation Operation**

- Check the Dust Cover for Cracks or Damage by Pushing it with Your Finger.
- Wheel Alignment Check and Adjustment (Refer to P.33A-6.)

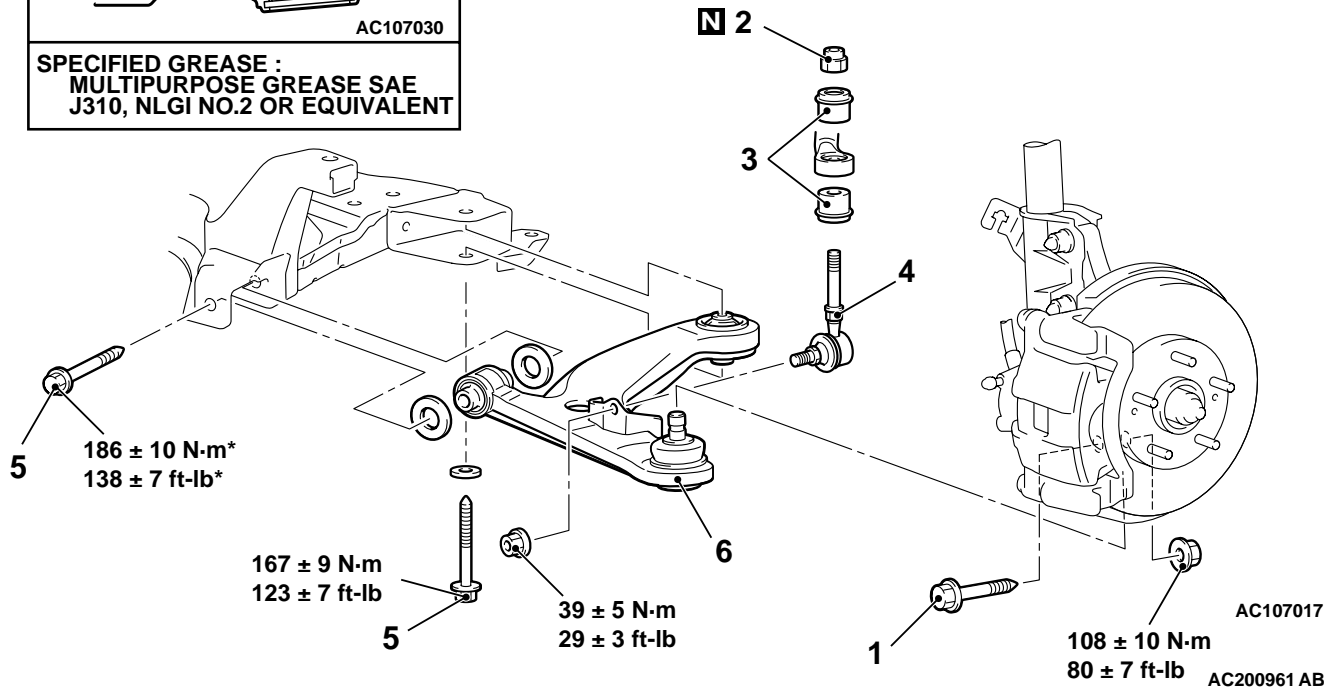
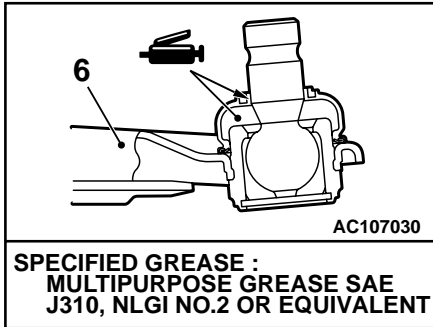

**REMOVAL STEPS**

1. LOWER ARM AND KNUCKLE CONNECTION
- >>A<< 2. SELF-LOCKING NUT
3. STABILIZER RUBBER

**REMOVAL STEPS (Continued)**

4. STABILIZER LINK ASSEMBLY CONNECTION
5. LOWER ARM AND CROSSMEMBER CONNECTION
6. LOWER ARM ASSEMBLY

## INSTALLATION SERVICE POINT

### >>A<< SELF-LOCKING NUT INSTALLATION

Tighten the self-locking nut until the stabilizer link thread part protruding length meets the standard value.

**Standard value (A):  $9.4 \pm 0.4$  mm ( $0.37 \pm 0.02$  inch)**

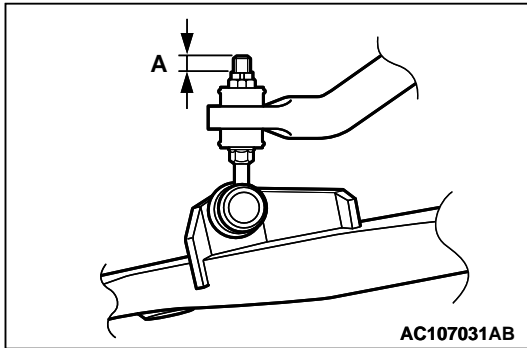

## INSPECTION

M1332001700156

- Check the bushing for wear and deterioration.
- Check the lower arm for bend or breakage.
- Check all bolts for condition and straightness.

## LOWER ARM BALL JOINT BREAKAWAY TORQUE CHECK

### Required Special Tool:

- MB991006: Preload Socket

1. After shaking the ball joint stud several times, use the special tool MB991006 to measure the breakaway torque of the ball joint.

**Standard value: 0 – 3.9 N·m (0 – 35 in-lb)**

2. If the measured value is not within the standard value, or if the ball joint is difficult to turn or does not turn smoothly, replace the lower arm assembly.

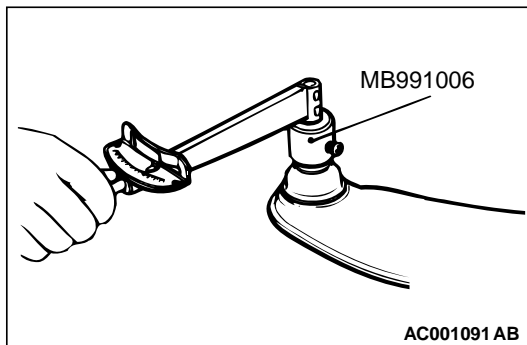

## LOWER ARM BALL JOINT DUST COVER CHECK

1. Check the dust cover for cracks or damage by pushing it with your finger.
2. If the dust cover is cracked or damaged, replace the lower arm.

*NOTE: Cracks or damage to the dust cover may cause damage to the ball joint. When it is damaged during service work, replace the dust cover.*

**BALL JOINT DUST COVER REPLACEMENT**

M1332008200185

**Required Special Tool:**

- MB990800: Ball Joint Remover and Installer

If the dust cover is damaged accidentally during service work, replace the dust cover as follows:

1. Remove the dust cover.
2. Apply the multipurpose grease SAE J310, NLGI No.2 or equivalent to the lip and the inside of a new dust cover.
 

**Grease amount for the inside the dust cover (reference): 8 – 10g (0.28 – 0.35 oz)**
3. Using the special tool MB990800, drive in the dust cover until it is fully seated.

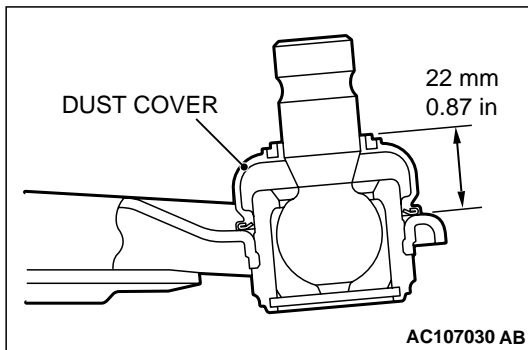
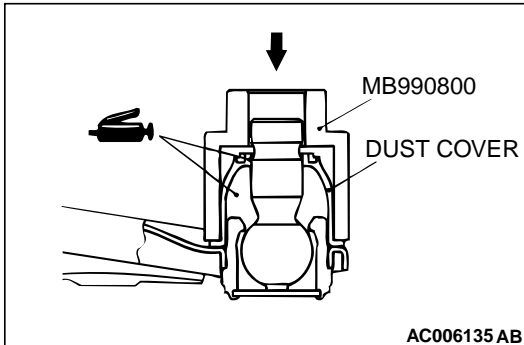

4. Position the dust cover as shown in the illustration. Make sure that there is no abnormal bulge or pressure applied on the dust cover.
5. Check the dust cover for cracks or damage by pushing it with your finger.

**LOWER ARM REAR BUSHING REPLACEMENT**

M1332008100229

**Required Special Tools:**

- MB990883: Rear Suspension Bushing Arbor
- MB990958: Rear Wheel Bearing and Installer Joint
- MB990887: Ring
- MB990890: Rear Suspension Bushing Base

Replace the bushing as follows:

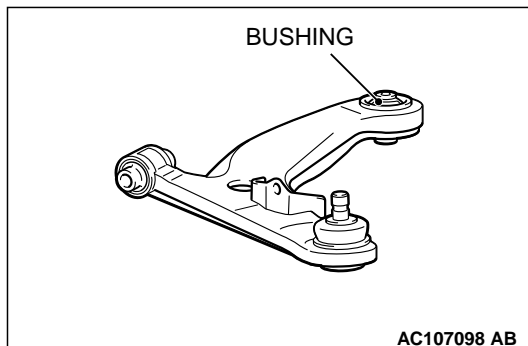

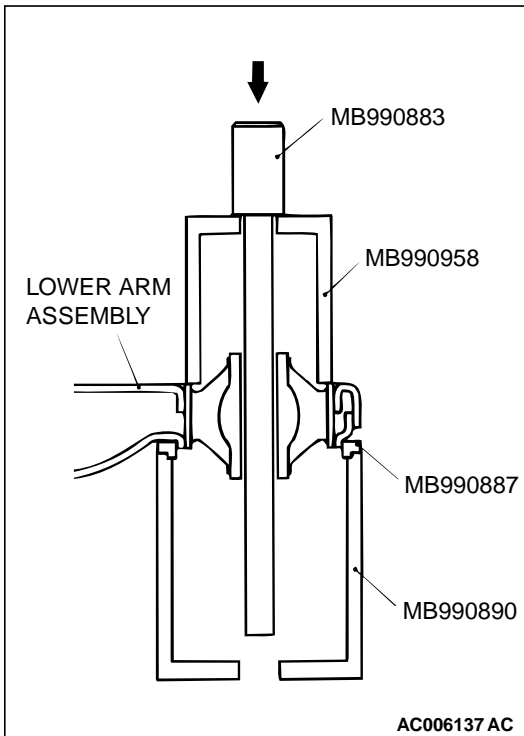

1. Use the special tools MB990883, MB990958, MB990887, and MB990890 to drive out the bushing.

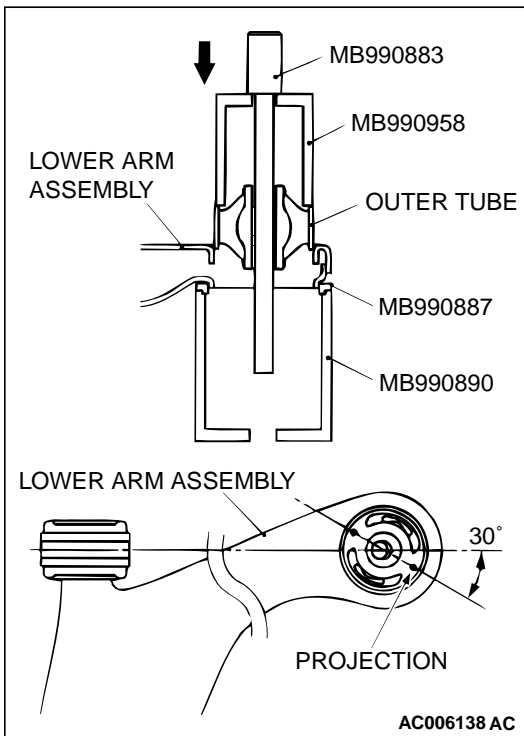

2. Position the bushing so that its projection is as shown, and then use the special tools MB990883, MB990958, MB990887, and MB990890 to press in the bushing.
3. Press the bushing until its outer tube is flush with the lower arm assembly surface.

**STABILIZER BAR****REMOVAL AND INSTALLATION**

M1332004000305

**⚠ CAUTION**

- Before removing the steering wheel and air bag module assembly, refer to GROUP 52B, Service Precautions P.52B-19 and Air Bag Module and Clock Spring P.52B-211. Also, put the front wheels in straight-ahead position. Failure to do so may damage the SRS clock spring and render the SRS air bag inoperative, which results serious driver injury.
- \*: Indicates parts which should be temporarily tightened, and then fully tightened with the vehicle on the ground in an unladen condition.

**Pre-removal Operation**

- Side Under Cover and Center Under Cover Removal (Refer to GROUP 51, Under Cover P.51-16.)
- Steering Wheel and Air Bag Module Assembly Removal (Refer to GROUP 37A, Steering Wheel P.37-22.)
- Clock Spring Removal (Refer to GROUP 52B, Air Bag Modules and Clock Spring P.52B-211.)
- Center Member Removal (Refer to GROUP 32, Engine Roll Stopper, Center Member P.32-6.)
- Front Exhaust Pipe Removal (Refer to GROUP 15, Exhaust Pipe and Main Muffler P.15-9.)

**Post-installation Operation**

- Front Exhaust Pipe Installation (Refer to GROUP 15, Exhaust Pipe and Main Muffler P.15-9.)
- Center Member Installation (Refer to GROUP 32, Engine Roll Stopper, Center Member P.32-6.)
- Clock Spring Installation (Refer to GROUP 52B, Air Bag Modules and Clock Spring P.52B-211.)
- Steering Wheel and Air Bag Module Assembly Installation (Refer to GROUP 37A, Steering Wheel P.37-22.)
- Check the Dust Covers for Cracks or Damage by Pushing it with Your Finger.
- Checking Steering Wheel Position with Wheels Straight Ahead
- Front Wheel Alignment Check and Adjustment (Refer to P.33A-6.)
- Side Under Cover and Center Under Cover Installation (Refer to GROUP 51, Under Cover P.51-16.)



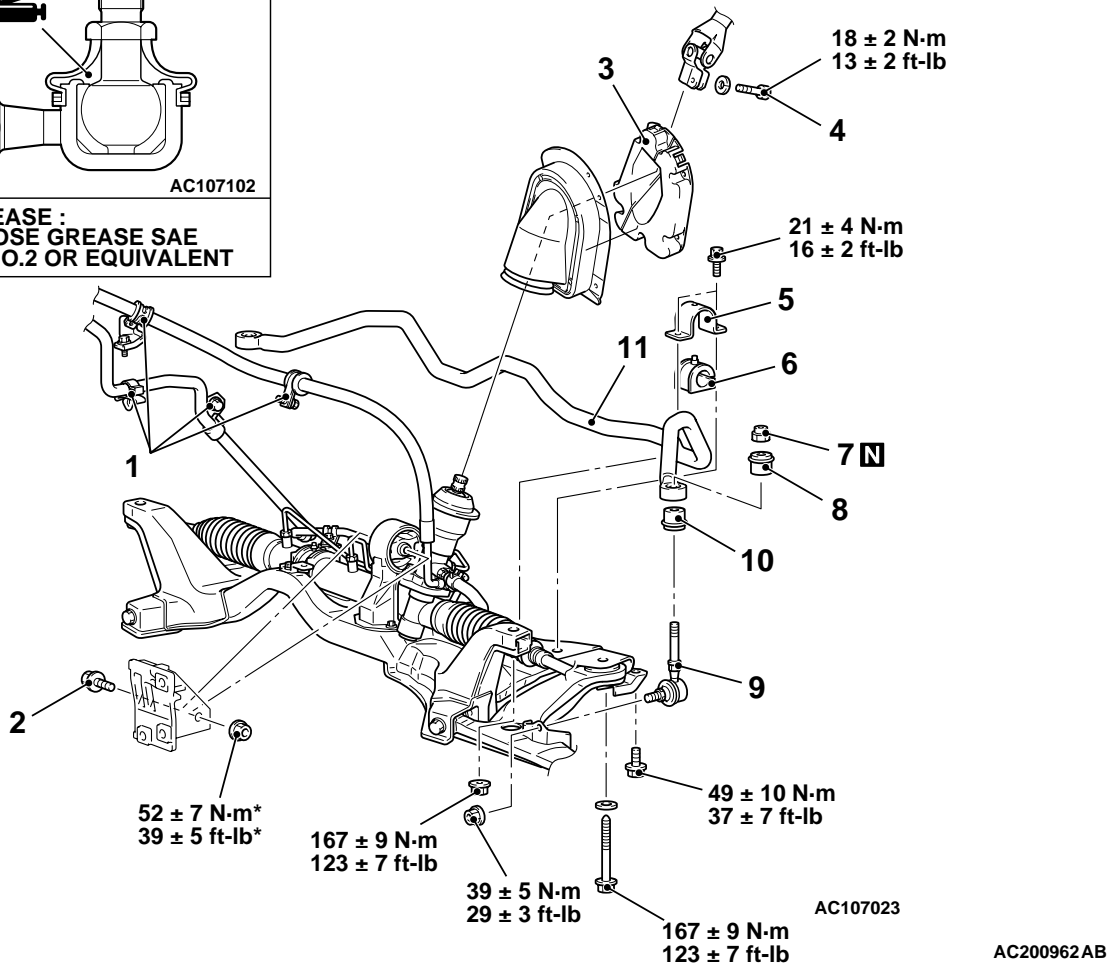
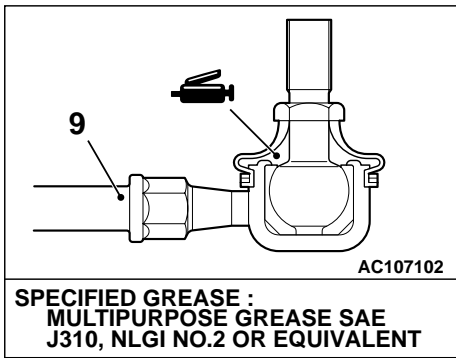

**REMOVAL STEPS**

1. POWER STEERING HOSE CLAMP
2. REAR ROLL STOPPER CONNECTING BOLT
3. STEERING SHAFT COVER
4. STEERING GEAR AND JOINT CONNECTING BOLT
5. FIXTURE

**REMOVAL STEPS**

6. BUSHING
7. SELF-LOCKING NUT
8. STABILIZER RUBBER
9. STABILIZER LINK
10. STABILIZER RUBBER
11. STABILIZER BAR

<<A>> >>A<<

<<A>> >>A<<

>>B<<

<<A>>

<<A>>

>>A<<

## REMOVAL SERVICE POINT

## &lt;&lt;A&gt;&gt; FIXTURE/BUSHING/STABILIZER LINK/STABILIZER BAR REMOVAL

Carry out the following operations to ensure working space in order to remove the fixtures, the bushings, the stabilizer links and the stabilizer bar.

1. Use a transmission jack to hold the crossmember, and then remove the crossmember mounting nuts and bolts.

**⚠ CAUTION**

Be careful not to lower the crossmember excessively, otherwise the power steering return hose bracket may deform.

2. Lower the crossmember until the fixtures, the bushings, the stabilizer links and the stabilizer bar can be removed.

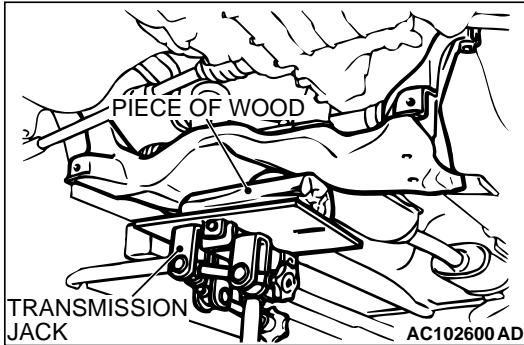

## INSTALLATION SERVICE POINTS

## &gt;&gt;A&lt;&lt; STABILIZER BAR/BUSHING/FIXTURE INSTALLATION

Align the stabilizer bar identification mark with the right end of the bushing (LH).

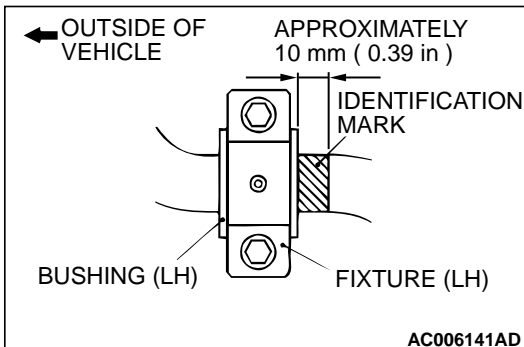

## &gt;&gt;B&lt;&lt; SELF-LOCKING NUT INSTALLATION

Tighten the self-locking nut until the stabilizer link thread part protruding length meets the standard value.

**Standard value (A):  $9.4 \pm 0.4$  mm ( $0.37 \pm 0.02$  inch)**

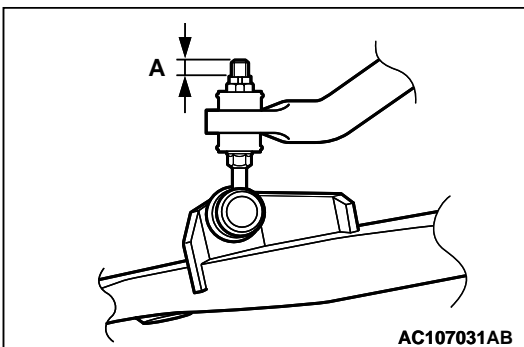

## INSPECTION

M1332002000149

- Check the bushings for wear and deterioration.
- Check the stabilizer bar for deterioration or damage.
- Check all bolts for condition and straightness.

### STABILIZER LINK BALL JOINT TURNING TORQUE CHECK

#### Required Special Tool:

- MB990326: Preload Socket

1. After shaking the ball joint stud several times, install the nut to the stud and use the special tool MB990326 to measure the turning torque of the ball joint.

**Standard value: 0.5 – 1.5 N·m (4.4 – 13.3 in-lb)**

2. When the measured value exceeds the standard value, replace the stabilizer link.
3. When the measured value is lower than the standard value, check that the ball joint turns smoothly without excessive play. If so, it is possible to re-use that ball joint.

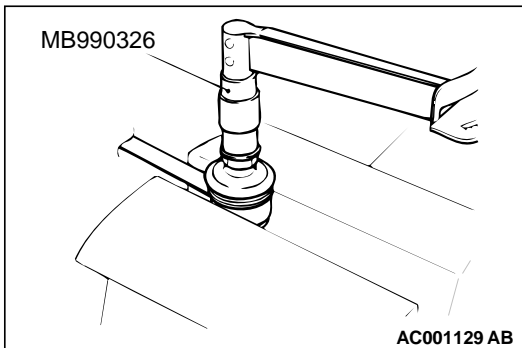

### STABILIZER LINK BALL JOINT DUST COVER CHECK

1. Check the dust cover for cracks or damage by pushing it with your finger.
2. If the dust cover is cracked or damaged, replace the stabilizer link.

*NOTE: Cracks or damage of the dust cover may cause damage to the ball joint. When it is damaged during service work, replace the dust cover. (Refer to P.33A-19.)*

### STABILIZER LINK BALL JOINT DUST COVER REPLACEMENT

M1332008300052

Only when the dust cover is damaged accidentally during service work, replace the dust cover as follows:

1. Remove the clip ring and the dust cover.
2. Apply the multipurpose grease SAE J310, NLGI No.2 or equivalent to the inside of a new dust cover.
3. Wrap plastic tape around the stabilizer link stud, and then install the dust cover to the stabilizer link.
4. Secure the dust cover by the clip ring.
5. Check the dust cover for cracks or damage by pushing it with finger.

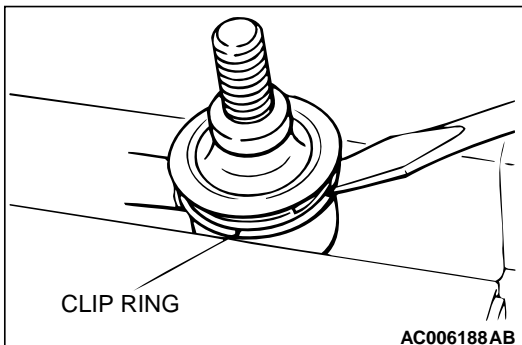

**SPECIFICATIONS****FASTENER TIGHTENING SPECIFICATIONS**

M1332008500119

ITEM	SPECIFICATION
<b>Lower arm assembly</b>	
Lower arm to crossmember connection bolt (Front)	186 ± 10 N·m (138 ± 7 ft-lb)
Lower arm to crossmember connection bolt (Rear)	167 ± 9 N·m (123 ± 7 ft-lb)
Lower arm to knuckle connection nut	108 ± 10 N·m (80 ± 7 ft-lb)
Lower arm to stabilizer link connection nut	39 ± 5 N·m (29 ± 3 ft-lb)
<b>Stabilizer bar</b>	
Crossmember brace bolt	49 ± 10 N·m (37 ± 7 ft-lb)
Crossmember to body connection bolt and nut	167 ± 9 N·m (123 ± 7 ft-lb)
Lower arm to stabilizer link connection nut	39 ± 5 N·m (29 ± 3 ft-lb)
Rear roll stopper connection nut	52 ± 7 N·m (39 ± 5 ft-lb)
Stabilizer fixture bolt	21 ± 4 N·m (16 ± 2 ft-lb)
Steering gear and joint connecting bolt	18 ± 2 N·m (13 ± 2 ft-lb)
<b>Strut assembly</b>	
Strut assembly self-locking nut	60 ± 10 N·m (45 ± 7 ft-lb)
Strut assembly to body connection nut	44 ± 5 N·m (33 ± 3 ft-lb)
Strut assembly to knuckle connection nut	167 ± 9 N·m (123 ± 7 ft-lb)

**GENERAL SPECIFICATIONS**

M1332000200114

**COIL SPRING**

ITEM	FWD	AWD
Wire diameter mm (in.)	14 (0.6)	14 (0.6)
Average diameter mm (in.)	160 (6.3)	160 (6.3)
Free length mm (in.)	325 (12.8)	340 (13.4)

**SERVICE SPECIFICATIONS**

M1332000300166

ITEM	SPECIFICATION	
Toe-in mm (in)	1 ± 2 (0.04 ± 0.09)	
Steering angle	Inner wheel	34°50' ± 1°30'
	Outer wheel (reference)	29°20'
Camber	0°00' ± 30' (Left/right deviation within 30')	
Caster	3°10' ± 30' (Left/right deviation within 30')	
Kingpin inclination	12°05' ± 1°30'	
Lower arm ball joint breakaway torque N·m (in-lb)	0 – 3.9 (0 – 35)	
Protruding length of stabilizer link thread part mm (in)	9.4 ± 0.4 (0.37 ± 0.02)	
Stabilizer link ball joint turning torque N·m (in-lb)	0.5 – 1.5 (4.4 – 13.3)	

**FRONT SUSPENSION  
SPECIFICATIONS**

**33A-21**

**LUBRICANT**

M1332000400044

ITEM		SPECIFIED LUBRICANT	QUANTITY
Lower arm ball joint	Lip portion of dust cover	Multipurpose grease SAE J310, NLGI No.2 or equivalent	As required
	Inside of dust cover		
Stabilizer link ball joint	Inside of dust cover		

---

## NOTES