

**INTRODUCTION**

- Car exterior features	1
- Identification data - Location of identification data on vehicle	2
- Dimensions - Weights	3
- Performance - Fuel consumption	5
- Capacities	6
- Characteristics of lubricants	7

**TECHNICAL DATA****ENGINE**

- Characteristics	8
- Typical curves	9
- Cylinder block/crankcase, crankshaft and associated components	10
- Counter-balance shafts	14
- Cylinder head assembly and valve gear timing	16
- Lubrication	19
- Cooling system - Fuel system - Supercharging	20

<b>CLUTCH</b>	21
---------------	----

<b>GEARBOX AND DIFFERENTIAL</b>	22
---------------------------------	----

<b>PROPELLER SHAFT</b>	25
------------------------	----

<b>REAR DIFFERENTIAL</b>	26
--------------------------	----

<b>BRAKING SYSTEM</b>	28
-----------------------	----

<b>STEERING</b>	30
-----------------	----

<b>WHEELS</b>	31
---------------	----

<b>FRONT SUSPENSION</b>	32
-------------------------	----

<b>REAR SUSPENSION</b>	33
------------------------	----

<b>ELECTRICAL EQUIPMENT</b>	35
-----------------------------	----

- Starting	36
- Recharging	38
- Electronic injection/ignition	40
- Over-boost device	45



3/4 front view

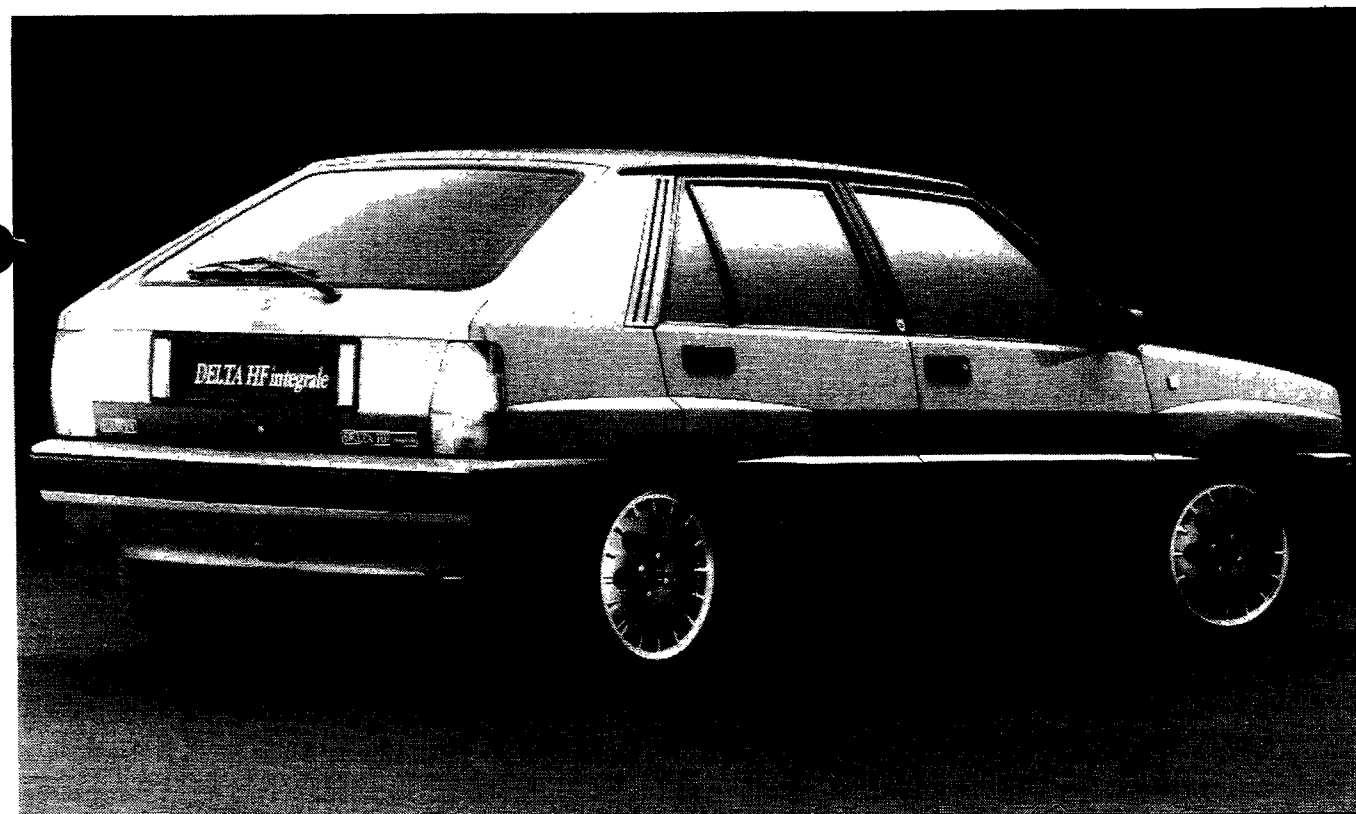

3/4 rear view

### 00.0

#### IDENTIFICATION DATA

	CHASSIS	ENGINE	VERSION	5 speed gearbox
 turbo	ZLA 831 ABO	831 C5.000	831 ABO 24	•

#### LOCATION OF IDENTIFICATION DATA ON VEHICLE

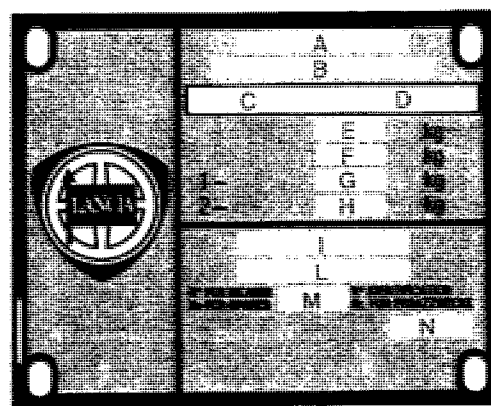
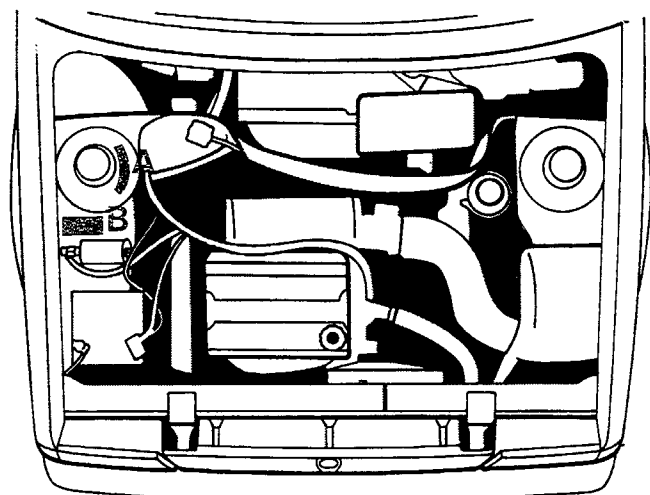

45198

#### A Chassis identification

- Vehicle type: (ZLA 831 ABO)
- chassis manufacture number.

**NOTE** *The engine type and number are stamped on the cylinder block/crankcase behind the engine oil cartridge filter.*

#### B V.I.N. Plate

- A. Name of Manufacturer.
- B. Type approval number.
- C. Vehicle type identification code.
- D. Chassis manufacture number.
- E. Maximum authorized weight of vehicle fully laden.
- F. Maximum authorized weight of vehicle fully laden plus tow.
- G. Maximum authorized weight on first axle (front).
- H. Maximum authorized weight on second axle (rear).
- I. Bodywork version code.
- L. Engine type.
- M. Spares number.
- N. Correct value of smoke absorption coefficient (for diesel engines).

#### Bodywork paint identification plate

Found inside the boot lid

- A. Paint manufacturer
- B. Description of colour
- C. Colour code
- D. Colour code for touching up or respraying

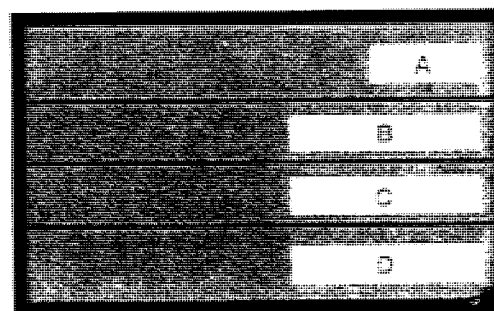

4318 B

### DIMENSIONS

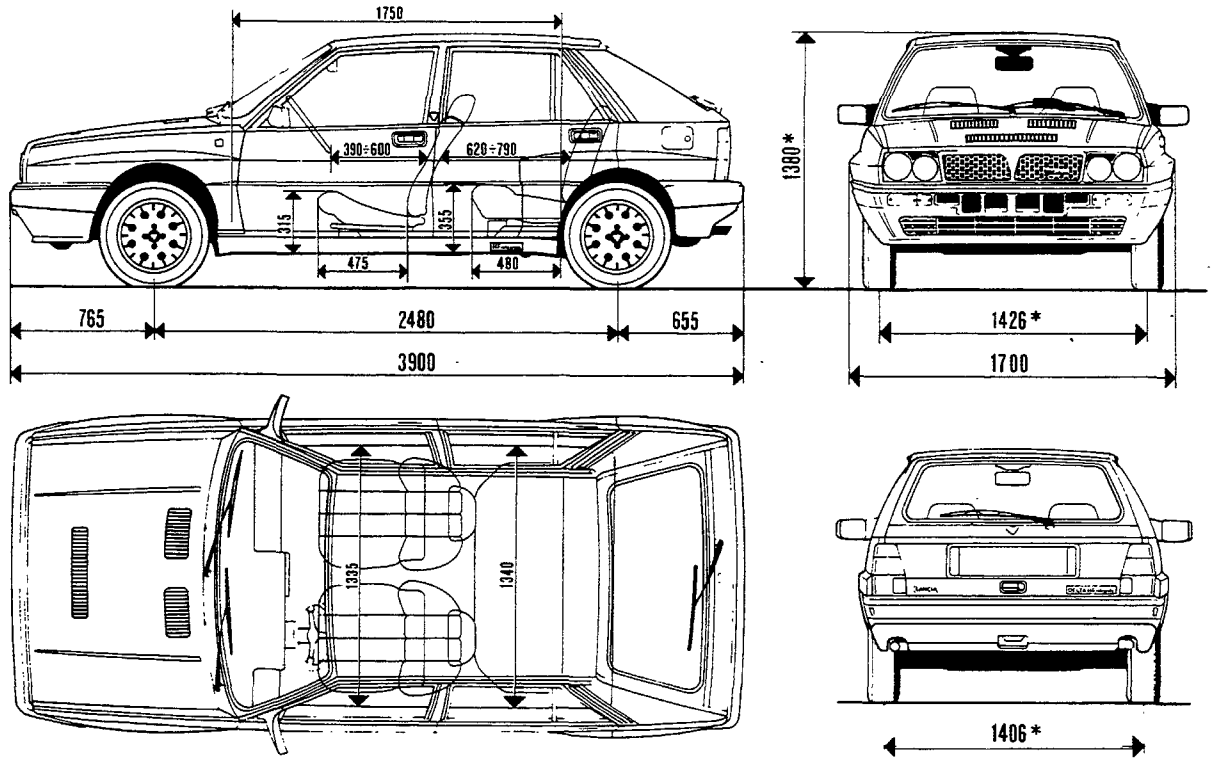

(\* ) Vehicle unladen

Luggage compartment capacity with rear seat backrest in normal position 200 dm (7.06 cu ft)<sup>3</sup>.

Luggage compartment capacity with rear seat folded down :940 dm (33.19 cu ft)<sup>3</sup>.

### WEIGHTS (in kg)



		1215
+ 450		1665
+		911
Kerb weight		754
		1200

**00.0**

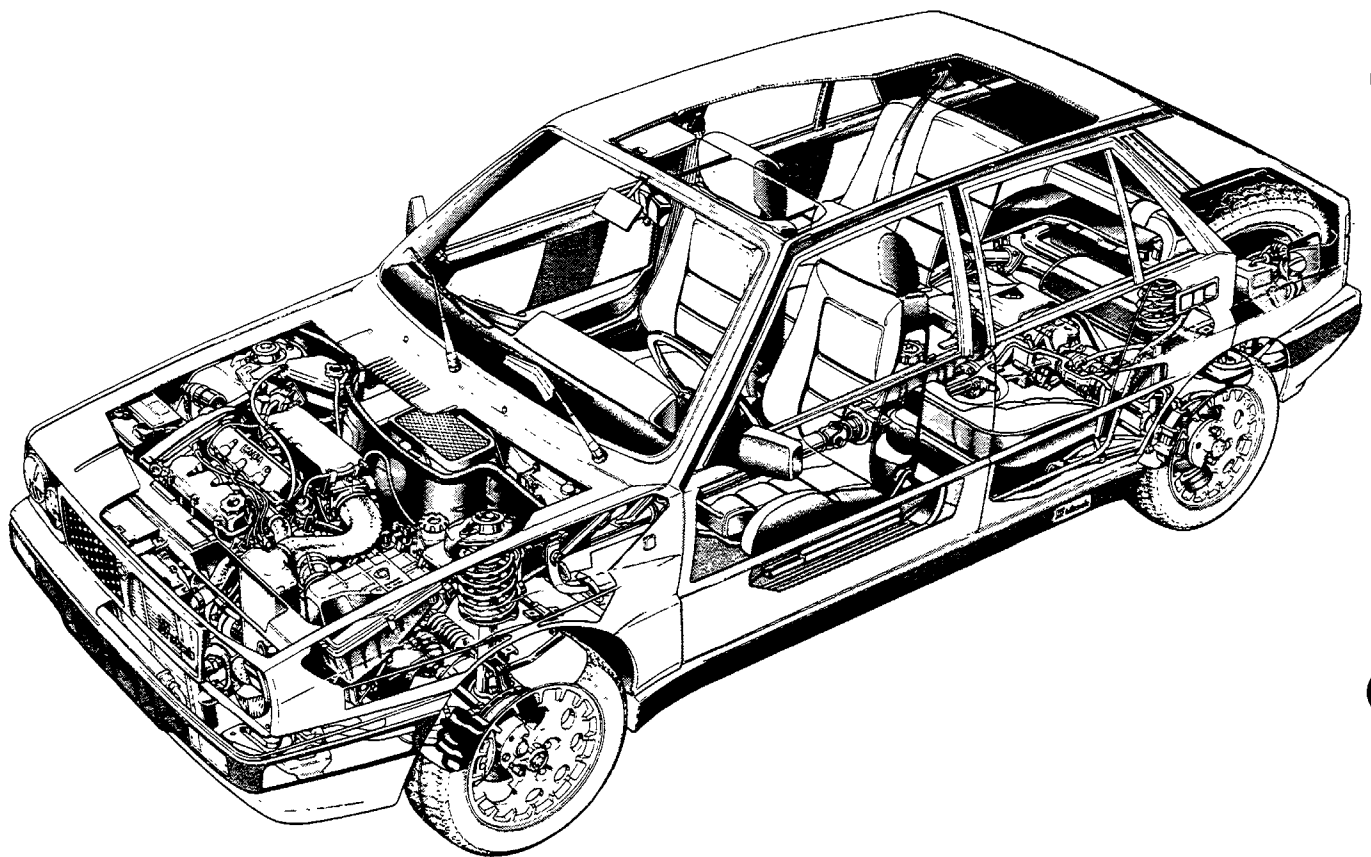
Layout of mechanical components

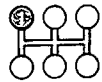
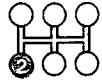
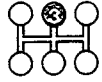
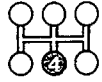
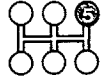
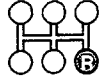
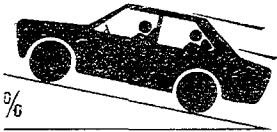
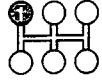
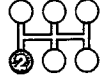
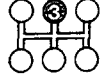
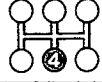
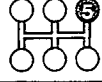

### PERFORMANCE

















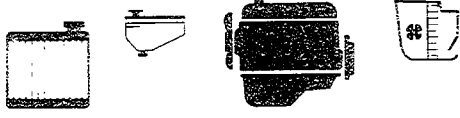









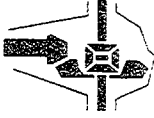

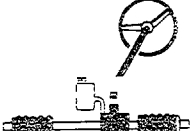
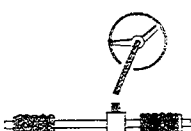
<p>Speed kph</p> 		60
		95
		140
		185
		215
		60
<p>Maximum climbable gradient</p> 		58
		41
		25
		17
		12
		68
<p>EEC fuel consumption figures (litres/100km)</p> 	Urban cycle (A)	10,8
	Constant speed 90 kph (B)	7,7
	Constant speed 120 kph (C)	10,2
	Average consumption (CCMC proposal) $\frac{A+B+C}{3}$	9,6

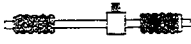
# Introduction

## Capacities

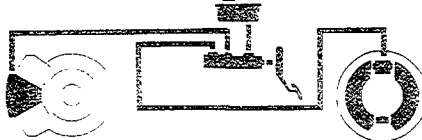
# DELTA HF integrale

### 00.0

Description	Unit		Quantity	
			dm <sup>3</sup>	(kg)
 Petrol O.R.(98-100)			57	-
50%  + 			6,2	-
	Total capacity of cooling system			
 VS+ Superstagionale (SAE 10 W) (SAE 20 W) (SAE 30) (SAE 40)	Total capacity 		5,9	5,0
VS+ Supermultigrado (SAE 15 W/40)			-	4,80
VS+ Turbo Synthesis (SAE 15 W/40)	Partial capacity (periodic replacement) 			
 a = TUTELA ZC 80S 			a	3,40
b = TUTELA GI/A 			b	-
 TUTELA W90/M DA	a 	b 	a	-
		Self-locking	b	1
 a = TUTELA GI/A	a 	b 	a	061
b = K 854			b	-
 c = TUTELA MRM2	c 		c	-
 TUTELA DOT 3	Total capacity 		-	0,30
 + 		3%	2	-
	~-10°C	50%		
	~-20°C	100%		

 Distilled water



# Characteristics of *Olio Fiat* lubricants for cars and commercial vehicles

Name of product	Description International designation	Usage
VS Super stagionale	SAE 40	Temperature 0°C ÷ > 35°C
	SAE 30	Temperature 0°C ÷ < 35°C
	SAE 20 W	Minimum temperature - 15°C ÷ 0°C
VS Super multigrado	SAE 10 W/30	Temperature below - 15°C ÷ 30°C
	SAE 15 W/40	Temperature - 15°C ÷ > 35°C
VS Turbo Syntesis SAE 15 W/40	Synthetic base detergent oil for petrol engines. Service API "SF". Exceeds European specification CCMC-G2	Temperature - 15°C ÷ > 40°C
VS Diesel Superstagionale	SAE 40	Temperature 0°C ÷ 50°C
	SAE 30	Temperature - 5°C ÷ 30°C
	SAE 20 W	Temperature - 15°C ÷ 15°C
VS Diesel Supermultigrado	SAE 10 W/30	Temperature below - 15°C ÷ 30°C
	SAE 15 W/40	Temperature - 15°C ÷ > 40°C
VS Turbo D	Oil for Diesel engines. Service API "CD". Satisfies standards MIL-L-2104 D and CCMC-PD1	Temperature - 15°C ÷ > 40°C
TUTELA ZC 80S	SAE 80/W oil. Satisfies standards MIL-L-2105 and API GL-4	Manual gearboxes and differentials
TUTELA ZC 90	SAE 80 W/90 non EP oil for manual gearboxes containing anti-wear additives	Non hypoid gearboxes and differential
TUTELA W 90/M DA	SAE 80 W/90 EP oil specially for normal and self-locking differentials. Satisfies standards MIL-L-2105 C and API GL5	Hypoid differentials Self-locking diffs. Steering boxes
TUTELA GI/A	"DEXRON II" type oil for automatic transmissions	Automatic gearboxes power assisted steering
TUTELA JOTA 1	Lithium soap based grease, consistency NLGI = 1	Greasing vehicle except for components particularly exposed to water requiring special greases
TUTELA MRM2	Lithium soap based water-repellant grease containing molybdenum disulphide, consistency NLGI = 2	Constant velocity joints
TUTELA MR3	Lithium soap based grease, consistency NLGI = 3	Wheel hub bearings, steering rods, various components
TUTELA DOT 3 TUTELA DOT 4	Fluid for hydraulic brakes, meeting standards USA FMVSS n. 116, SAE J 1703, ISO 4925. CUNA NC-956-01	Hydraulic brakes and hydraulically operated clutches
K 854	Lithium soap based grease, consistency NLGI = 000, containing molybdenum disulphide	Rack and pinion steering boxes
SP 349	Special: castor oil and sodium soap based grease containing graphite and molybdenum disulphide, compatible with brake fluid and brake circuit rubber seals	Load proportioning valve Load proportioning valve rod
Liquido Autofà DPI	Alcohol based detergent fluid	To be used undiluted or diluted for windscreen and headlamp washers
Liquido Paraflù <sup>®</sup> FIAT	Mono-ethylene glycol based anti-freeze for cooling system	Cooling circuits Percentage to be used 35% up to - 25°C 50% up to - 35°C
Diesel Mix	Additive with protective action for Diesel engines	To be mixed with diesel fuel (17 cc per 10 litres)

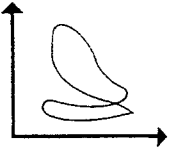

### 00.10

#### CHARACTERISTICS

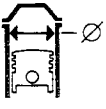
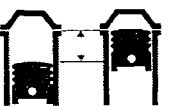
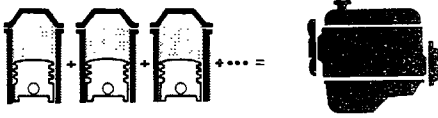
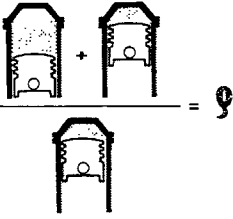
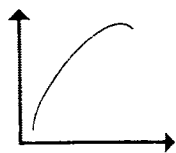
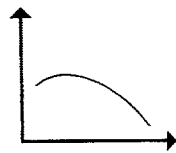
			831 C5.000
	Cycle		OTTO 4 stroke
	Number of cylinders		4
	Cylinder liner (bore)	mm	84
	Stroke	mm	90
	Capacity	cc	1995
	Compression ratio		8 ± 0,1
	Max power EEC	kW (CV)	133 (185)
		rpm	5300
	Max torque EEC	daNm (kgm)	29,8 (31)
		rpm	3500

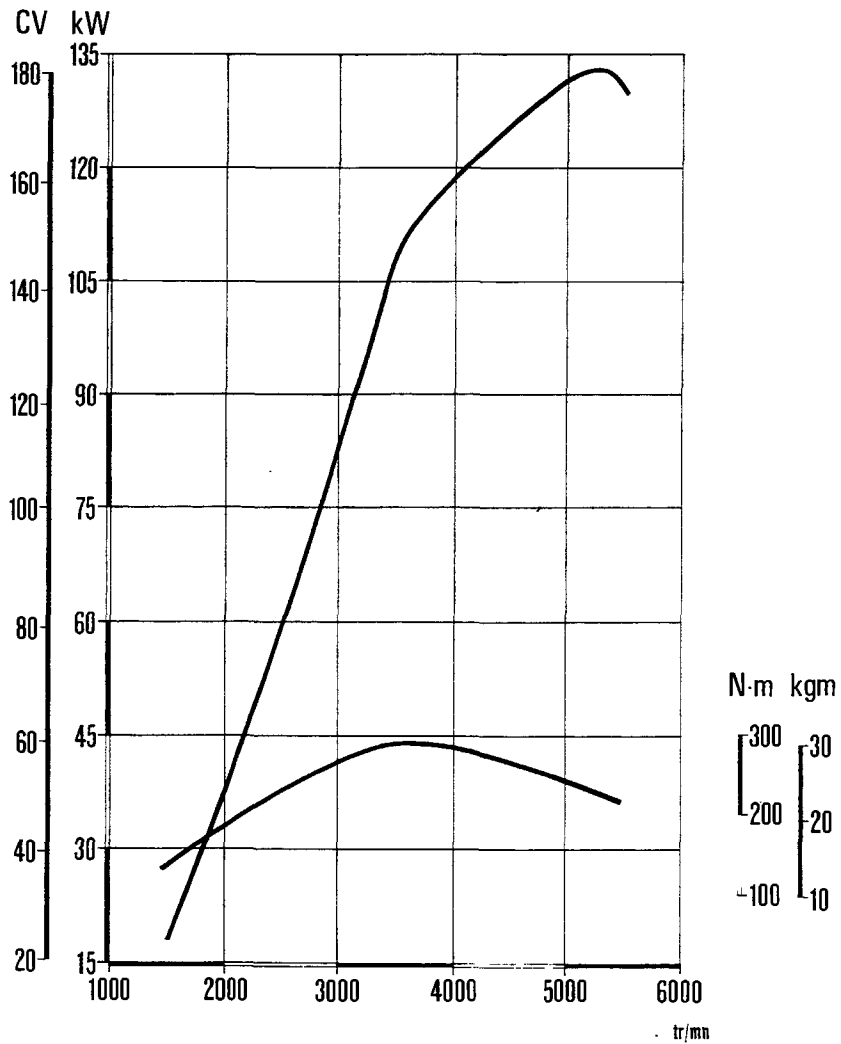

### Engine power curves obtained by EEC method

The power curves illustrated can be obtained with the engine overhauled and run in, without a fan and with an exhaust silencer and air filter fitted at sea level.

### Test bench cycles for overhauled engines

During the bench test for the overhauled engines it is not advisable to run the engines at maximum speed but to stick to the figures prescribed in the table; complete the running in of the actual engines in the vehicle.

Test speed (rpm)	Time in minutes	Load on the brakes
800 ÷ 1000	10'	no load
1500	10'	no load
2000	10'	no load





# Technical data



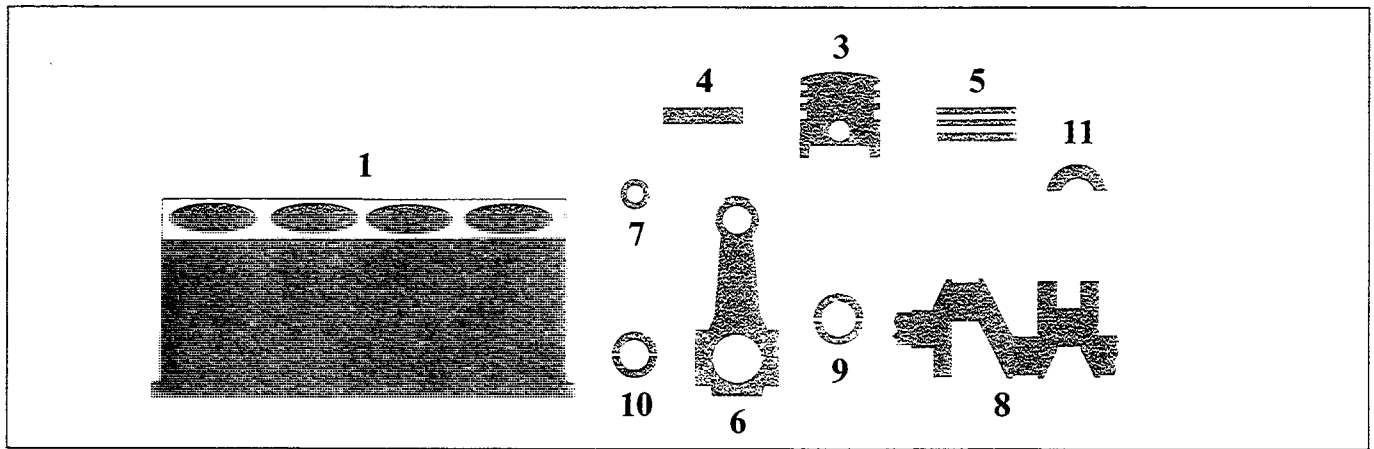

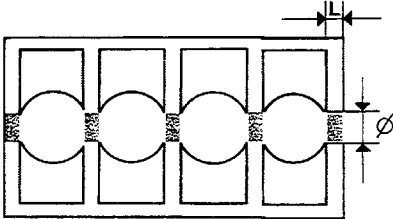

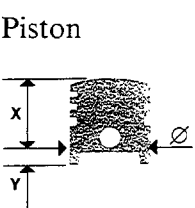

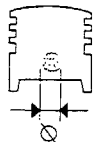
# DELTA HF integrale

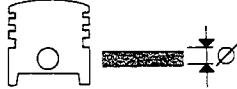
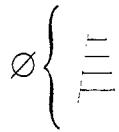
Engine: cylinder block/crankcase, crankshaft and associated components

00.10

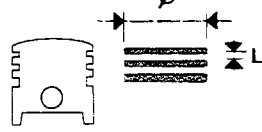
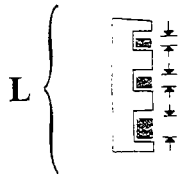

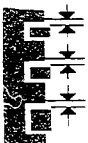
DESCRIPTION		Values in mm
 <p>1 Main bearing supports</p>	L	23,100 ÷ 23,200
	A	56,717 ÷ 56,723
	B	56,723 ÷ 56,729
	C	56,729 ÷ 56,735
 <p>Cylinder bore <math>\varnothing \left( \begin{array}{c} \text{---} \\ \text{---} \\ \text{---} \end{array} 0,010 \right)</math></p>		84,000 ÷ 84,050
 <p>3 Piston</p>	Y	25
	A	83,940 ÷ 83,950
	C	83,960 ÷ 83,970
	E	83,980 ÷ 83,990
	$\varnothing \text{ LANCIA} >$	0,4
 <p>3 Difference in weight between pistons</p>		± 5 g
 <p>3-1 Piston-Cylinder bore</p>		0,050 ÷ 0,070
 <p>3 Gudgeon pin housing</p>	1	21,996 ÷ 21,999
	2	21,999 ÷ 22,002

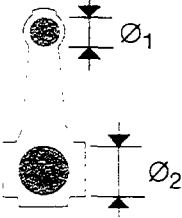
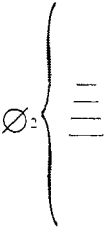
DESCRIPTION		Values in mm		
4	 Gudgeon pin	 $\varnothing$ LANCIA >	1	21,991 ÷ 21,994
			2	21,994 ÷ 21,997
				0,2
4-3	 Gudgeon pin - Housing			0,002 ÷ 0,008
3	 Piston ring grooves		1	1,535 ÷ 1,555
			2	2,020 ÷ 2,040
			3	3,967 ÷ 3,987
5	 Piston rings	 $\varnothing$ LANCIA >	1	1,478 ÷ 1,490
			2	1,987 ÷ 1,990
			3	3,925 ÷ 3,937
				0,4
5-3	 Piston rings Piston ring grooves		1	0,045 ÷ 0,077
			2	0,030 ÷ 0,062
			3	0,030 ÷ 0,062
5-1	 Opening at end of rings in cylinder bore		1	0,30 ÷ 0,50
			2	0,30 ÷ 0,50
			3	0,25 ÷ 0,40
6	 Small end bush housing Big end bearing housing	 $\varnothing_1$ $\varnothing_2$		24,988 ÷ 25,021
			1	53,904 ÷ 53,910
			2	53,898 ÷ 53,904
			3	53,892 ÷ 53,898

# Technical data

# DELTA HF integrale

Engine: cylinder block/crankcase, crankshaft and associated components

00.10

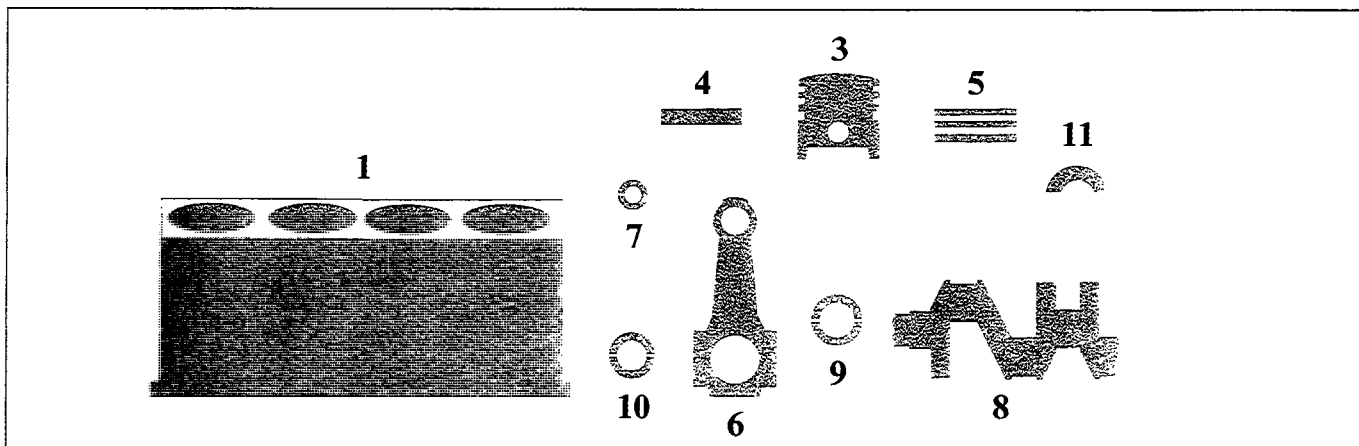

DESCRIPTION		Values in mm	
<p>7 Small end bush</p>	$\left. \begin{array}{l} \text{---} \\ \text{---} \\ \text{---} \end{array} \right\} \begin{array}{l} 1 \\ 2 \end{array}$	$\text{Ø}_1$	25,065 ÷ 25,090
			22,004 ÷ 22,007
			22,007 ÷ 22,010
<p>4-7 <math>\Rightarrow \Leftarrow</math> <math>\rightarrow \leftarrow</math></p>	Gudgeon pin Small end bush		0,010 ÷ 0,016
<p>7-6 <math>\Rightarrow \Leftarrow</math> <math>\rightarrow \leftarrow</math></p>	Small end bush Bush housing		0,044 ÷ 0,102
<p>8 Main journals Crank pins</p>	$\left. \begin{array}{l} \text{---} \\ \text{---} \\ \text{---} \\ \text{---} \\ \text{---} \\ \text{---} \end{array} \right\} \begin{array}{l} A \\ B \\ C \\ 1 \\ 2 \\ 3 \\ L \end{array}$	$\text{Ø}_1$	52,998 ÷ 53,004
			52,992 ÷ 52,998
			52,986 ÷ 52,992
			50,799 ÷ 50,805
			50,793 ÷ 50,799
			50,787 ÷ 50,793
	27,975 ÷ 28,025		
<p>9 Crankshaft bearings</p>	$\left. \begin{array}{l} \text{---} \\ \text{---} \\ \text{---} \end{array} \right\} \begin{array}{l} A \\ B \\ C \end{array}$	$\text{Ø}$	0,838 ÷ 1,844
			1,844 ÷ 1,850
			1,850 ÷ 1,856
			0,254 ÷ 0,508
	$\text{Ø}$ LANCIA <		





DESCRIPTION		Values in mm
9-8	 Crankshaft bearings - Main journals	0,025 ÷ 0,049
10	 Big end bearings  Ø LANCIA <	A
		B
		C
10-8	 Big end bearings - Main journals	0,033 ÷ 0,057
11	 Thrust washers S LANCIA >	S
11-8	 Crankshaft end float	0,055 ÷ 0,305

Diagram showing fitting of connecting rod-piston assembly and direction of rotation in engine

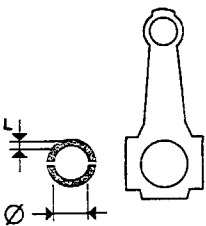

1 = Area where matching number of cylinder bore to which connecting rod belongs is stamped.

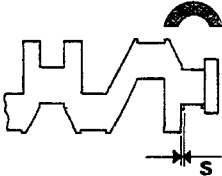
The arrow shows the direction of rotation of the engine as seen from the timing side.

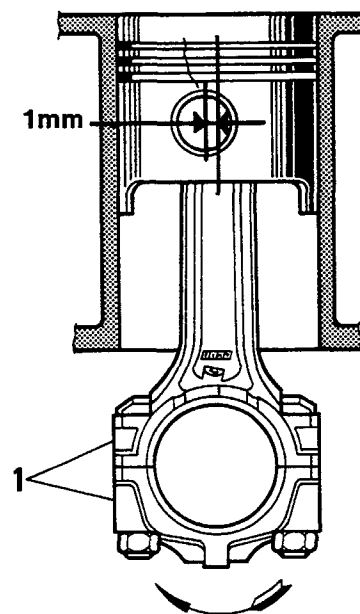
1mm = Gudgeon pin offset on the piston.

# Technical data

# DELTA HF integrale

Engine: counter-balance shafts

00.10

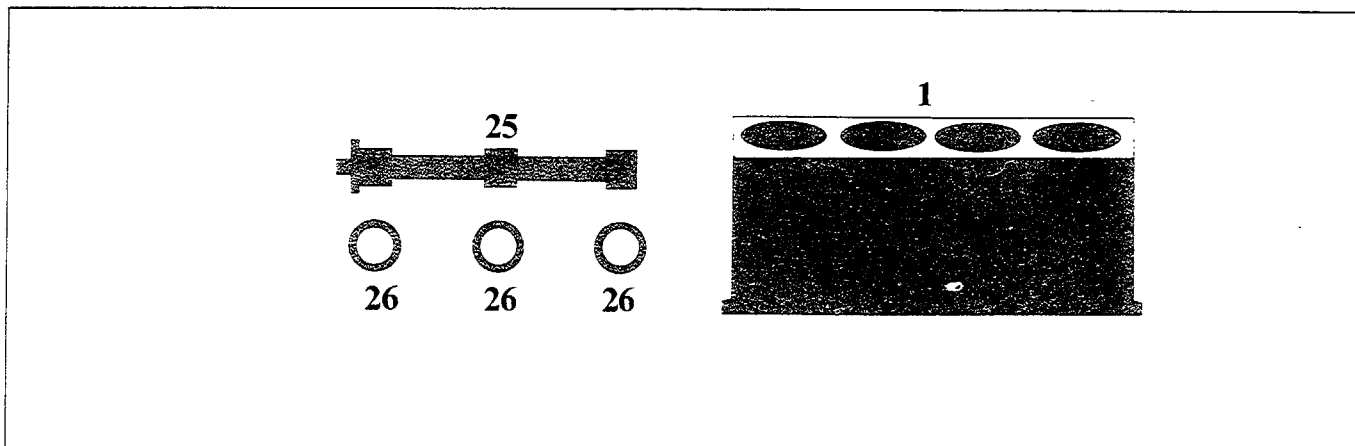

DESCRIPTION		Values in mm
25	Counter-balance shafts	n° 2
	Shafts driven	by toothed belt
26		$\varnothing_1$ 36,920 ÷ 36,940
		$\varnothing_2$ 37,020 ÷ 37,040
		$\varnothing_3$ 38,020 ÷ 38,040
25		$\varnothing_1$ 36,850 ÷ 36,870 $\varnothing_2$ 36,950 ÷ 36,970 $\varnothing_3$ 37,950 ÷ 37,970
25-26		0,050 ÷ 0,090
26-1		0,080 ÷ 0,140
	Shaft bearings-Bushes	0,050 ÷ 0,090
	Shaft bushes Cylinder block/crankcase seats	0,080 ÷ 0,140

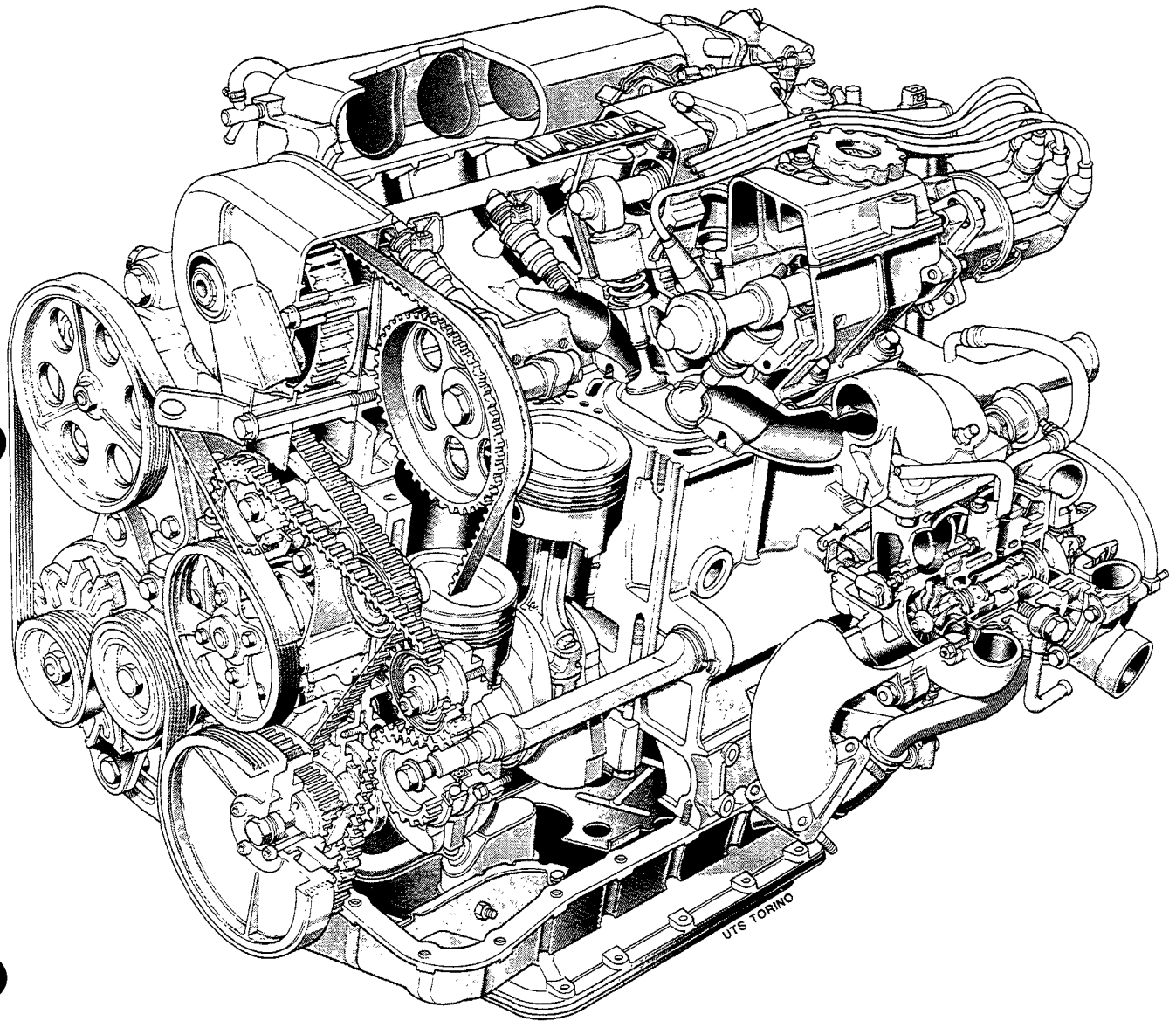

**Partial cross section of engine**



# Technical data





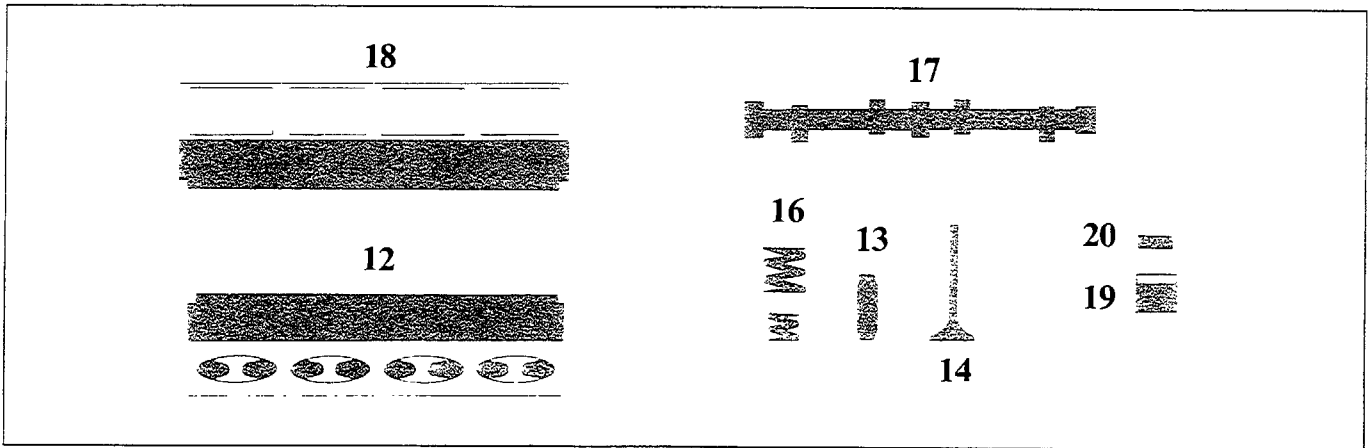

# DELTA HF integrale

## Engine: cylinder head assembly and valve gear components

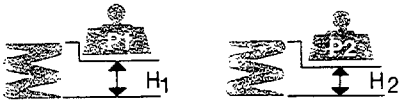
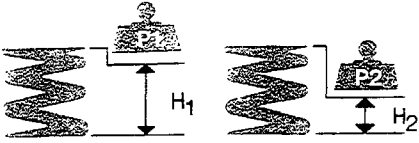
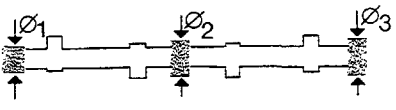
00.10

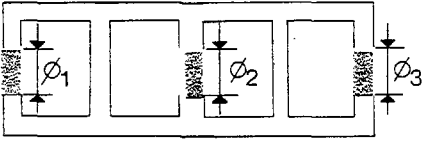
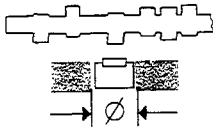

DESCRIPTION		Values in mm	
12	<p>Valve guide bore in cylinder head</p>	Ø	13,950 ÷ 13,977
		<p>Valve seats</p>	$45^\circ \pm 5'$ $45^\circ \pm 5'$ $\sim 2$
13	<p>Valve guides</p>	Ø <sub>1</sub>	8,022 ÷ 8,040
		$\left. \begin{matrix} \text{Ø}_2 \\ \text{Ø}_2 \end{matrix} \right\} \begin{matrix} \rightarrow \\ \rightarrow \end{matrix}$	$14,040 \div 14,058$ $13,988 \div 14,016$
		Ø <sub>2</sub> : LANCIA >	0,05-0,10-0,25
13-12	<p>Valve guide Bore in cylinder head</p>	$\left. \begin{matrix} \rightarrow \\ \rightarrow \end{matrix} \right\}$	$0,063 \div 0,108$ $0,021 \div 0,066$
		14	<p>Valves</p>
$\left. \begin{matrix} \rightarrow \\ \rightarrow \\ \alpha \end{matrix} \right\}$	$7,974 \div 7,992$ $35,850 \div 36,450$ $45^\circ 30' \pm 5'$		
$\left. \begin{matrix} \rightarrow \\ \rightarrow \\ \alpha \end{matrix} \right\}$	$7,974 \div 7,992$ $35,850 \div 36,450$ $45^\circ 30' \pm 5'$		
$\left. \begin{matrix} \rightarrow \\ \rightarrow \\ \alpha \end{matrix} \right\}$	$7,974 \div 7,992$ $35,850 \div 36,450$ $45^\circ 30' \pm 5'$		
$\left. \begin{matrix} \rightarrow \\ \rightarrow \\ \alpha \end{matrix} \right\}$	$7,974 \div 7,992$ $35,850 \div 36,450$ $45^\circ 30' \pm 5'$		
$\left. \begin{matrix} \rightarrow \\ \rightarrow \\ \alpha \end{matrix} \right\}$	$7,974 \div 7,992$ $35,850 \div 36,450$ $45^\circ 30' \pm 5'$		

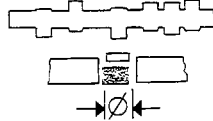
DESCRIPTION		Values in mm	
14-13	 Valves - Valve guides		0,030 ÷ 0,066
15	 Internal valve spring	P <sub>1</sub>	14,13 ÷ 15,11 daN
		H <sub>1</sub>	31
		P <sub>2</sub>	26,39 ÷ 28,74 daN
		H <sub>2</sub>	21,5
16	 External valve spring	P <sub>1</sub>	36,68 ÷ 39,6 daN
		H <sub>1</sub>	36
		P <sub>2</sub>	55,91 ÷ 60,82 daN
		H <sub>2</sub>	26,5
17	 Camshaft bearings	∅ <sub>1</sub>	29,944 ÷ 29,960
		∅ <sub>2</sub>	45,755 ÷ 45,771
		∅ <sub>3</sub>	46,155 ÷ 46,171
18	 Cam lift		9,1
			8,6
18	 Camshaft bearings in camshaft housing	∅ <sub>1</sub>	30,009 ÷ 30,034
		∅ <sub>2</sub>	45,800 ÷ 45,825
		∅ <sub>3</sub>	46,200 ÷ 46,225
18	 Tappet housings	∅	37,000 ÷ 37,025
17-18	 Camshaft bearings Camshaft housing supports	∅ <sub>1</sub>	0,049 ÷ 0,090
		∅ <sub>2</sub> -∅ <sub>3</sub>	0,029 ÷ 0,070
19	 Tappet	∅	36,975 ÷ 36,995





# Technical data

# DELTA HF integrale

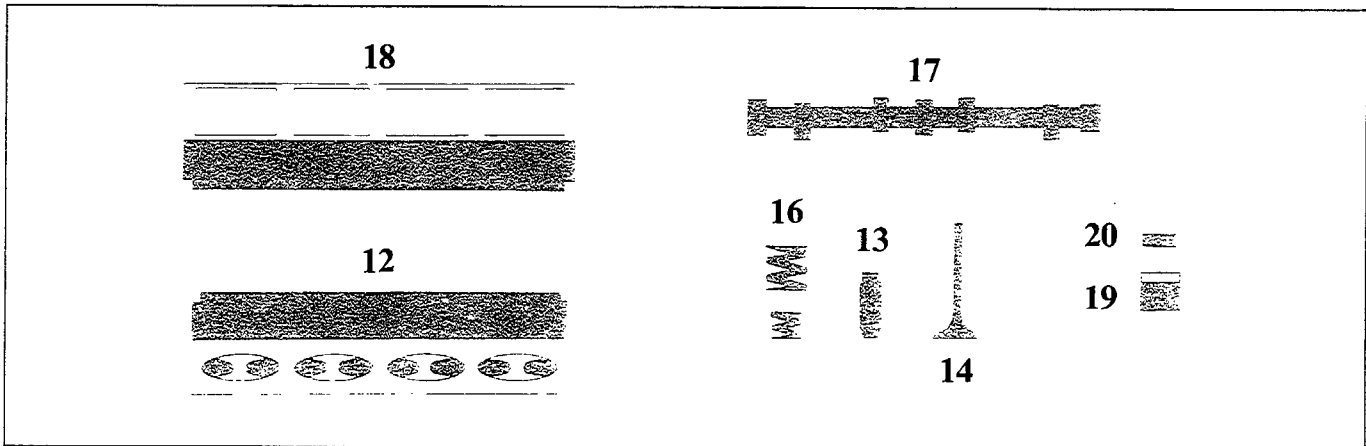

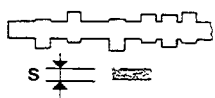

Engine: cylinder head assembly and valve gear components

00.10



DESCRIPTION		Values in mm
19-18	 Tappet Housing in cylinder head	0,005 ÷ 0,050
20	 Shim	$S \left( \begin{matrix} \text{---} \\ \text{---} \\ \text{---} \end{matrix} 0,05 \right)$ 3,25 ÷ 4,70
17-20	 clearance for timing check	0,80
	 operational clearance	0,80
		0,35 ÷ 0,04
		0,40 ÷ 0,04

## TIMING ANGLES

inlet	 opens BTDC	8°
	 closes ABDC	42°
exhaust	 opens BTDC	42°
	 closes ABDC	1°

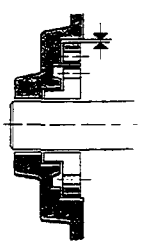
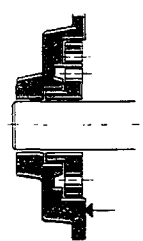
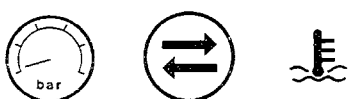
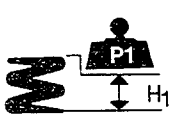
		Values in mm
Oil pump		lobe gears
Pump operated		through crankshaft
Oil pressure relief valve		incorporated in crankshaft front cover
 <p>between pump casing and driven gear</p>		0,080 ÷ 0,186
 <p>between upper side of gears and pump cover</p>		0,025 ÷ 0,056
Full flow filter		cartridge
Insufficient oil pressure sender unit		electrical
 <p>Operating pressure at a temperature of 100 °C</p>		3,4 ÷ 4,9 bar (3,5 ÷ 5 kg/cm <sup>2</sup> )
 <p>Oil pressure relief valve spring</p>	P <sub>1</sub>	11,1 ÷ 12,1 daN
	H <sub>1</sub>	35,3