

1992 Mazda 323 Protegé Workshop Manual

FOREWORD

This workshop manual is intended for use by service technicians of Authorized Mazda Dealers to help them service Mazda vehicles.

For proper repair and maintenance, a thorough familiarization with this manual is important, and it should always be kept in a handy place for quick and easy reference.

All the contents of this manual, including drawings and specifications, are the latest available at the time of printing. As modifications affecting repair or maintenance occur, relevant information supplementary to this volume will be made available at Mazda dealers. This manual should be kept up-to-date.

Mazda Motor Corporation reserves the right to alter the specifications and contents of this manual without obligation or advance notice.

All rights reserved. No part of this book may be reproduced or used in any form or by any means, electronic or mechanical—including photocopying and recording and the use of any kind of information storage and retrieval system—without permission in writing.

**Mazda Motor Corporation
HIROSHIMA, JAPAN**

APPLICATION:

This manual is applicable to vehicles beginning with the Vehicle Identification Numbers (VIN) shown on the following page.

CONTENTS

Title		Section
General Information		GI
Pre-Delivery Inspection and Scheduled Maintenance Services		A
Engine	SOHC	B1
	DOHC	B2
Lubrication System		D
Cooling System		E
Fuel and Emission Control System		F
Engine Electrical System		G
Clutch		H
Manual Transaxle	F5M-R	J1
	G5M-R	J2
Automatic Transaxle		K
Front and Rear Axles		M
Steering System		N
Braking System		P
Wheels and Tires		Q
Suspension		R
Body		S
Body Electrical System		T
Heater and Air Conditioner Systems		U
Technical Data		TD
Special Tools		ST
Parts Index		PI
Wiring Diagram (Part No. 5209-10-91F) (9999-95-019G-92)		Z

© 1991 Mazda Motor Corporation
PRINTED IN USA, JUL. '91
1270-10-91G
(9999-95-017B-92)

VEHICLE IDENTIFICATION NUMBERS (VIN)

PROTEGÉ

JM1 BG223 * NO 400001 ~
JM1 BG224 * NO 400001 ~
JM1 BG225 * NO 400001 ~
JM1 BG226 * NO 400001 ~

3-DOOR HATCHBACK

JM1 BG231 * NO 400001 ~
JM1 BG232 * NO 400001 ~
JM1 BG233 * NO 400001 ~

GENERAL INFORMATION

IMPORTANT INFORMATION	GI- 2
BASIC ASSUMPTIONS	GI- 2
SAFETY RISK	GI- 2
POSSIBLE LOSS OF WARRANTY	GI- 2
WARNING ON LUBRICANTS AND GREASES	GI- 2
HOW TO USE THIS MANUAL	GI- 3
PREPARATION	GI- 3
REPAIR PROCEDURE.....	GI- 3
SYMBOLS.....	GI- 4
NOTES, CAUTIONS, AND WARNINGS.....	GI- 4
FUNDAMENTAL PROCEDURES	GI- 4
PROTECTION OF THE VEHICLE	GI- 4
A WORD ABOUT SAFETY	GI- 5
PREPARATION OF TOOLS AND MEASURING EQUIPMENT	GI- 5
SPECIAL TOOLS.....	GI- 5
REMOVAL OF PARTS.....	GI- 5
DISASSEMBLY	GI- 5
REASSEMBLY	GI- 6
ADJUSTMENTS	GI- 7
RUBBER PARTS AND TUBING	GI- 7
JACK AND SAFETY STAND POSITIONS	GI- 8
VEHICLE LIFT (2-SUPPORT TYPE)	
POSITIONS.....	GI- 8
TOWING.....	GI- 9
IDENTIFICATION NUMBER LOCATIONS.....	GI-10
UNITS	GI-10
ABBREVIATIONS	GI-10
CAUTION	GI-11
INSTALLATION OF MOBILE TWO-WAY RADIO SYSTEM	GI-11
REMOVAL OF IGNITION KEY ON AUTOMATIC TRANSAXLE MODEL.....	GI-11
ELECTRICAL TROUBLESHOOTING TOOLS	GI-12
CAUTION WITH ELECTRICAL PARTS.....	GI-13

IMPORTANT INFORMATION**BASIC ASSUMPTIONS**

This workshop manual assumes that you have certain special tools that are necessary for the safe and efficient performance of service operations on Mazda vehicles and that you know how to use them properly. It also assumes that you are familiar with automobile systems and basic service and repair procedures. You should not attempt to use this manual unless these assumptions are correct and you understand the consequences described below.

SAFETY RISK

This manual contains certain notes, warnings, and other precautionary information that you should carefully read and follow to reduce the risk of personal injury to yourself or others and the risk of improper service that may damage the vehicle or render it unsafe. If there is no such information in regard to any specific service method, this does not mean there is no possibility that personal safety or vehicle safety will be jeopardized by the use of incorrect methods or tools.

POSSIBLE LOSS OF WARRANTY

The manufacturer's warranty on Mazda vehicles and engines can be voided if improper service or repairs are performed by persons other than those at an Authorized Mazda Dealer.

WARNING ON LUBRICANTS AND GREASES

Avoid all prolonged and repeated contact with mineral oils, especially used oils. Used oils contaminated during service (e.g., engine sump oils) are more irritating and more likely to cause serious effects, including skin cancer, in the event of gross and prolonged skin contact.

Wash skin thoroughly after work involving oil.

Protective hand cleaners may be of value provided they can be removed from the skin with water. Do not use gasoline, paraffin, or other solvents to remove oil from the skin.

Lubricants and greases may be slightly irritating to the eyes.

Repeated or prolonged skin contact should be avoided by wearing protective clothing if necessary. Particular care should be taken with used oils and greases containing lead. Do not allow work clothing to be contaminated with oil. Dry clean or launder such clothing at regular intervals.

9MUGIX-002

HOW TO USE THIS MANUAL

PREPARATION

PREPARATION points out the needed **Special Service Tool (SST)** for the service operation that it proceeds. Gather all necessary **SST** before beginning work.

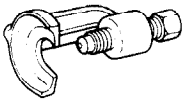

Example:

MANUAL STEERING		PREPARATION	
SST		SST NUMBER	USAGE
49 0118 850C		49 0118 850C	For removal of tie-rod end
Puller, ball joint		Puller, ball joint	
		SST NAME	SST ILLUSTRATION

9MUGIX-033

REPAIR PROCEDURE

1. Most repair operations begin with an overview illustration. It identifies the components, shows how the parts fit together, and visual parts inspections. If a damaged or worn part is found, repair or replace it as necessary.
2. Expendable parts, tightening torques, and symbols for oil, grease, and sealant are shown in the overview illustration.
3. Pages related to service procedures are shown under the illustration. Refer to this information when servicing the related part.

Example:

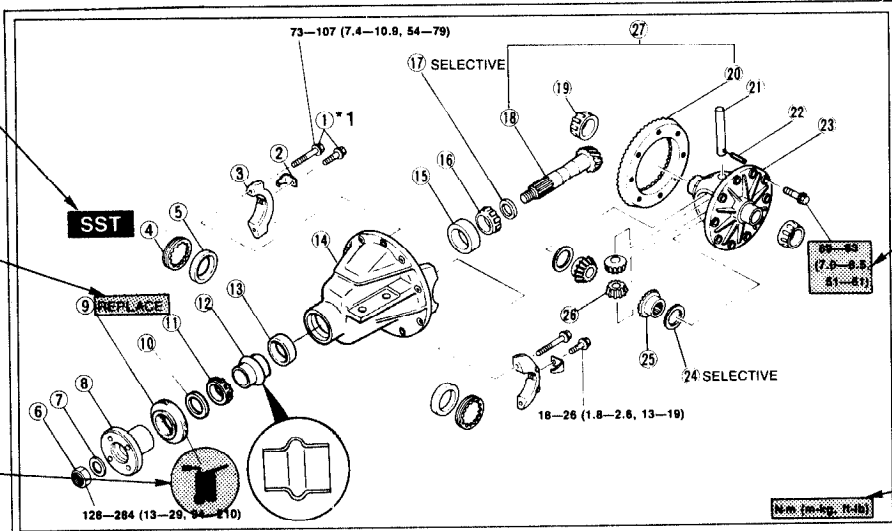

SHOWS NEEDED SST (points to SST callout box)

SHOWS EXPENDABLE PARTS (points to 'REPLACE' callout)

SHOWS APPLICATION POINT OF OIL, ETC. (points to oil application symbol)

SHOWS TIGHTENING TORQUE SPECIFICATION *2 (points to torque callout box)

SHOWS TIGHTENING TORQUE UNIT (points to 'N·m (m·kg, ft·lb)' callout)

SHOWS VISUAL INSPECTION INFORMATION (points to 'inspect for damage or rough rotation' callout)







SHOWS RELATED PAGE FOR SERVICE (points to 'Removal page M-21' callout)

1. Bolt	16. Bearing inner race
2. Lock plate	Removal..... page M-22
3. Bearing cup	Inspect for damage or rough rotation.....
4. Adjusting screw	Installation..... page M-24
5. Bearing outer race	17. Spacer
6. Locknut	18. Drive pinion
7. Washer	Removal..... page M-21
8. Companion flange	Inspect splines and teeth for wear or damage..... page M-22
Removal..... page M-21	Adjustment of height..... page M-22
Inspect splines and teeth for wear or damage.....	Adjustment..... page M-24

*1: The numbering (ex. ①) shows service procedure.
 *2: Units shown in N·m (m·kg, ft·lb) unless otherwise specified.

SYMBOLS

There are six symbols indicating oil, grease, and sealant. These symbols show the points of applying such materials during service.

Symbol	Meaning	Kind
	Apply oil	New engine oil or gear oil as appropriate
	Apply brake fluid	Only brake fluid
	Apply automatic transaxle fluid	Only ATF
	Apply grease	Appropriate grease
	Apply sealant	Appropriate sealant
	Apply petroleum jelly	Appropriate petroleum jelly

23UGIX-001

Note

- When special oil or grease is needed, this is shown in the illustration.

NOTES, CAUTIONS, AND WARNINGS

As you read through the procedures, you will come across NOTES, CAUTIONS, and WARNINGS. Each one is there for a specific purpose. **NOTES** give you **added information** that will help you to complete a particular procedure. **CAUTIONS** are given to prevent you from making an error that could **damage the vehicle**. **WARNINGS** remind you to be especially careful in those areas where carelessness can cause **personal injury**. The following list contains some general WARNINGS you should follow when you work on a vehicle.

9MUGIX-036

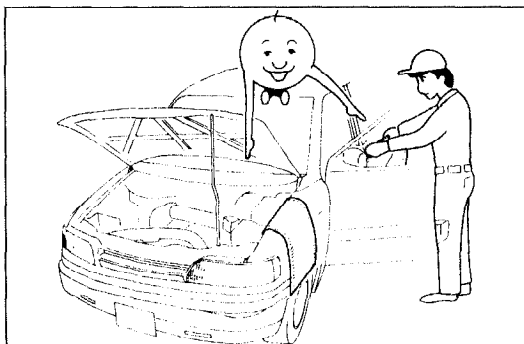

9MUGIX-037

FUNDAMENTAL PROCEDURES**PROTECTION OF THE VEHICLE**

Always be sure to cover fenders, seats, and floor areas before starting work.

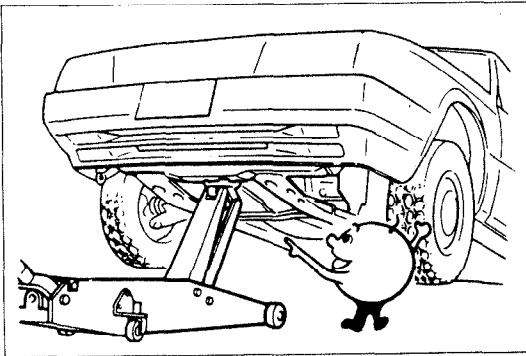

9MUGIX-003

A WORD ABOUT SAFETY

The following precautions must be followed when jacking up the vehicle.

1. Block the wheels.
2. Use only the specified jacking positions.
3. Support the vehicle with safety stands.

Start the engine only after making certain the engine compartment is clear of tools and people.

GI

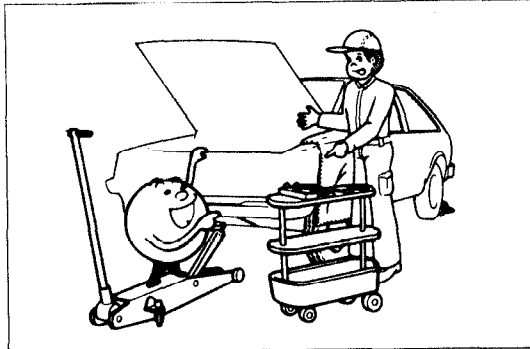

9MUGIX-038

PREPARATION OF TOOLS AND MEASURING EQUIPMENT

Be sure that all necessary tools and measuring equipment are available before starting any work.

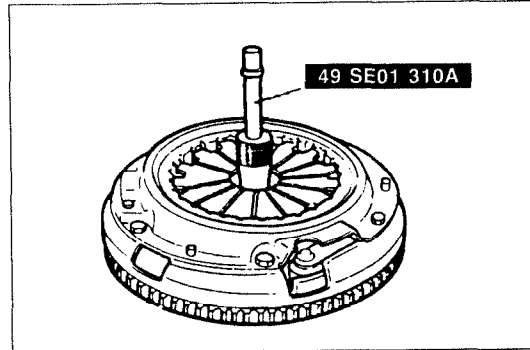

47U0GX-005

SPECIAL TOOLS

Use special tools when they are required.

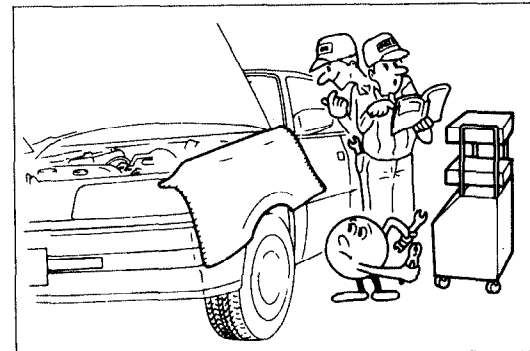

47U0GX-006

REMOVAL OF PARTS

While correcting a problem, try also to determine its cause. Begin work only after first learning which parts and subassemblies must be removed and disassembled for replacement or repair.

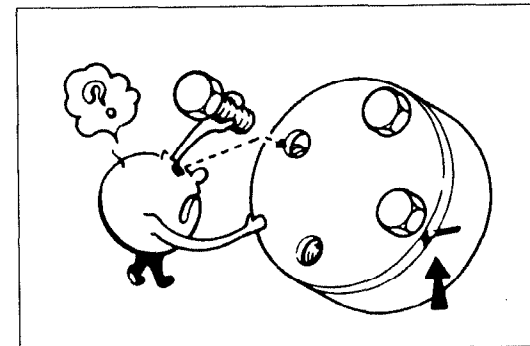

9MUGIX-039

DISASSEMBLY

If the disassembly procedure is complex, requiring many parts to be disassembled, all parts should be disassembled in a way that will not affect their performance or external appearance and identified so that reassembly can be performed easily and efficiently.

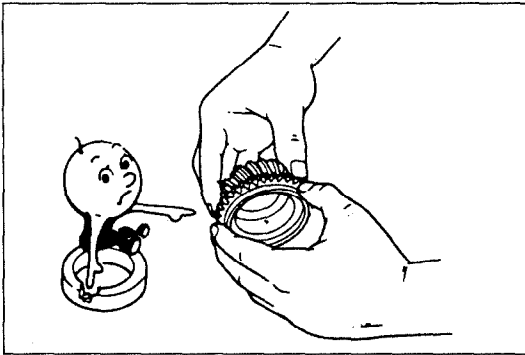

9MUGIX-040

1. Inspection of parts

When removed, each part should be carefully inspected for malfunctioning, deformation, damage, and other problems.

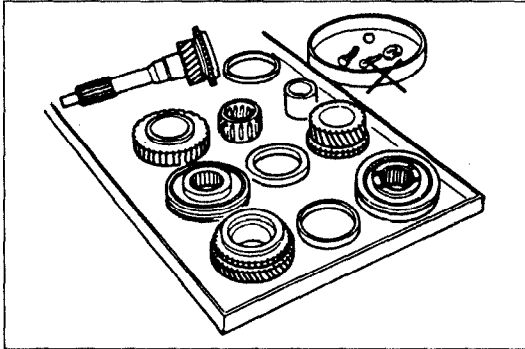

9MUGIX-041

2. Arrangement of parts

All disassembled parts should be carefully arranged for re-assembly.

Be sure to separate or otherwise identify the parts to be replaced from those that will be reused.

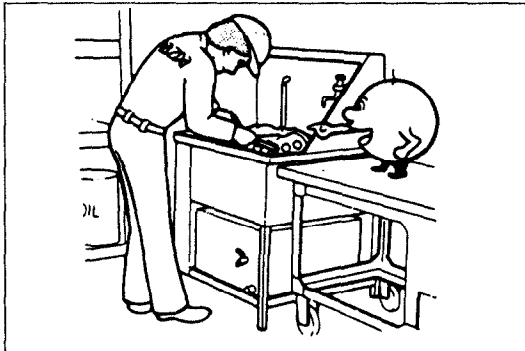

47U0GX-010

3. Cleaning parts for reuse

All parts to be reused should be carefully and thoroughly cleaned in the appropriate method.

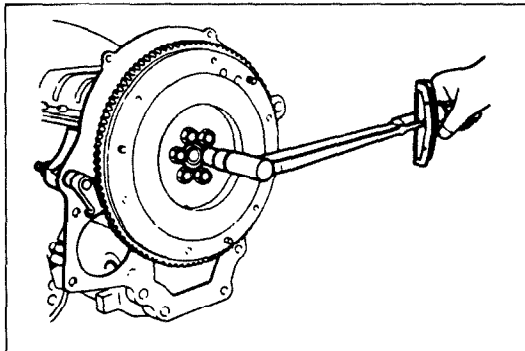

9MUGIX-004

REASSEMBLY

Standard values, such as torques and certain adjustments, must be strictly observed in the reassembly of all parts. Refer to STANDARD BOLT AND NUT TIGHTENING TORQUE in Section TD for tightening torques not mentioned in the main text.

If removed, these parts should be replaced with new ones:

- | | |
|----------------|-----------------|
| 1. Oil seals | 2. Gaskets |
| 3. O-rings | 4. Lock washers |
| 5. Cotter pins | 6. Nylon nuts |

Depending on location:

1. Sealant should be applied or new gaskets used.
2. Oil should be applied to the moving components of parts.
3. Specified oil or grease should be applied at the prescribed locations (such as oil seals) before reassembly.

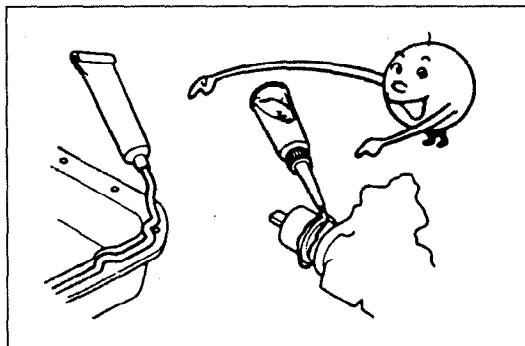

23UGIX-004

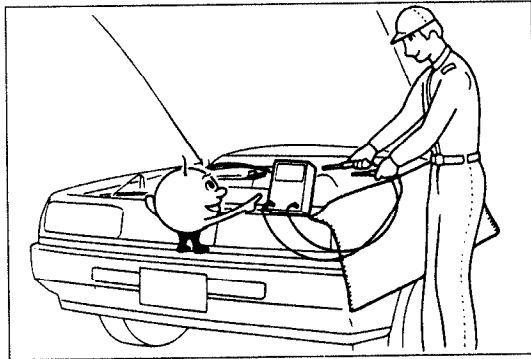

67U0GX-002

ADJUSTMENTS

Use suitable gauges and/or testers when making adjustments.

GI

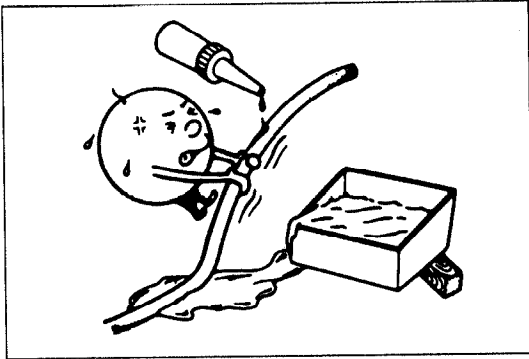

9MUGIX-005

RUBBER PARTS AND TUBING

Prevent gasoline or oil from getting on rubber parts or tubing.

JACK AND SAFETY STAND POSITIONS

FRONT END

Jack position:

At the front crossmember

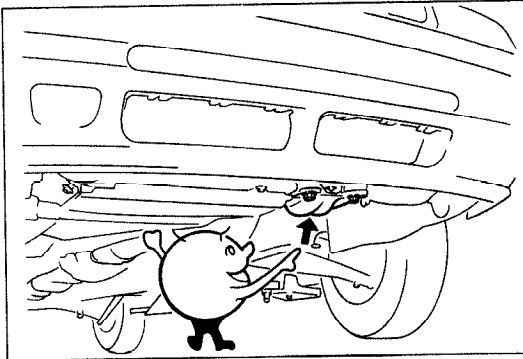

03UGIX-007

Safety stand positions:

On both sides of the body frame

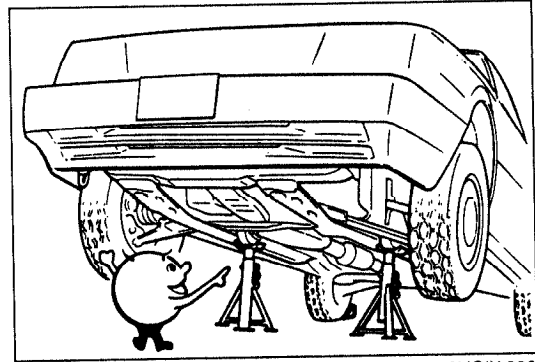

03UGIX-008

REAR END

Jack position:

At the center of the rear crossmember

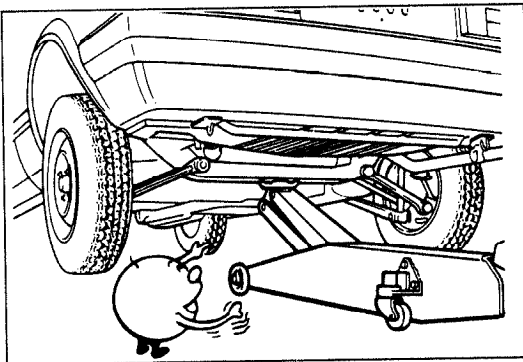

23UGIX-002

Safety stand positions:

On both sides of the body frame

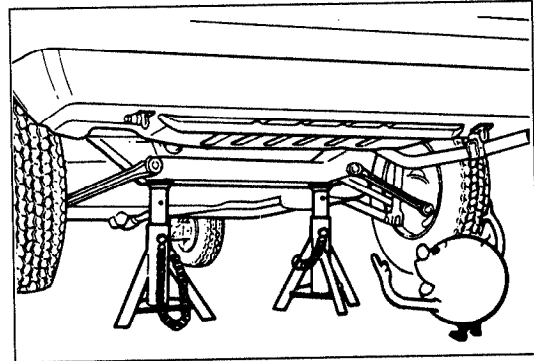

03UGIX-010

VEHICLE LIFT (2-SUPPORT TYPE) POSITIONS

FRONT END

Frame

Side sills

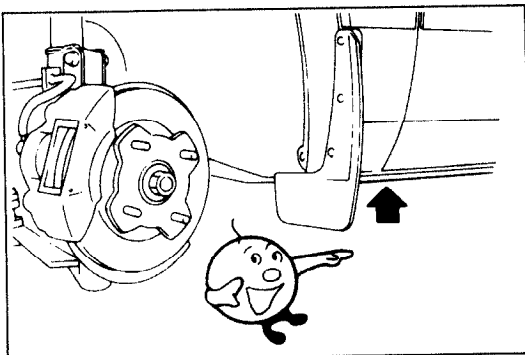

9MUGIX-010

REAR END

Frame

Side sills

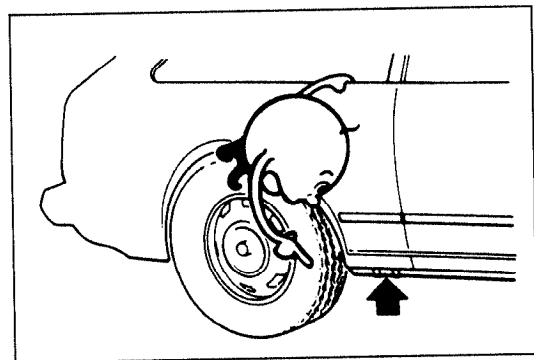

9MUGIX-011

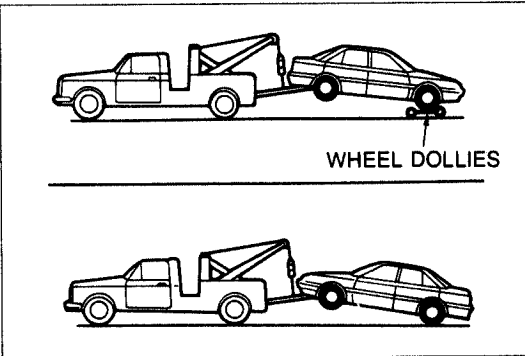

03UGIX-002

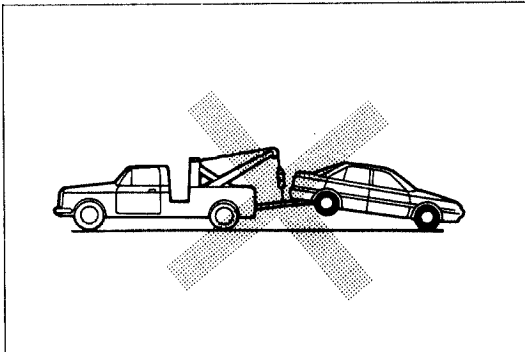

TOWING

Proper towing equipment is necessary to prevent damage to the vehicle.

Laws and regulations applicable to vehicles in tow must always be observed.

As a general rule, towed vehicles should be pulled with the driving wheels off the ground. If excessive damage or other conditions prevent towing the vehicle with the driving wheels off the ground, use wheel dollies.

With either automatic or manual transaxle:

1. Set the ignition switch in the ACC position;
2. Place the selector lever or shift lever in N (Neutral);
3. Release the parking brake.

Caution

- **Do not tow the vehicle backward with driving wheels on the ground. This may cause internal damage to the transaxles.**
- **Do not use the hook loops under the front and rear of the vehicle for towing purposes. These hook loops are designed ONLY for transport tie-down. If tie-down hook loops are used for towing, the front/rear bumper will be damaged.**

TIE-DOWN HOOKS — FRONT

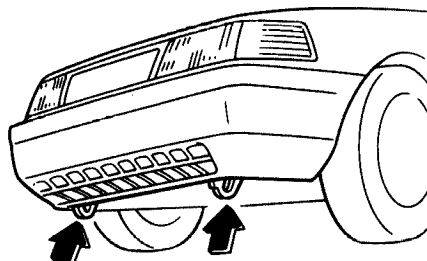

TIE-DOWN HOOKS — REAR (HATCHBACK)

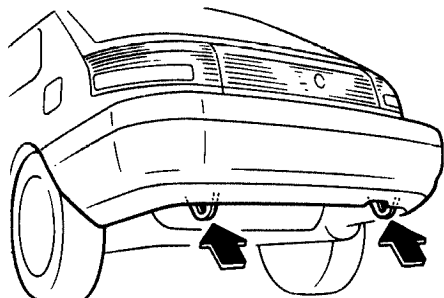

TIE-DOWN HOOKS — REAR (PROTEGÉ)

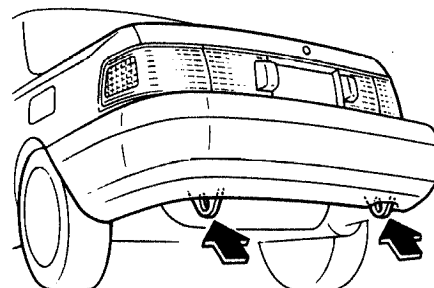

IDENTIFICATION NUMBER LOCATIONS

VEHICLE IDENTIFICATION NUMBER (VIN)

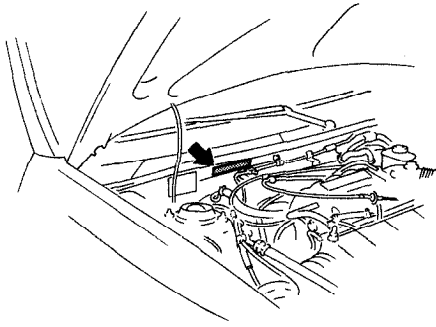

AUTOMATIC TRANSAXLE MODEL AND NUMBER

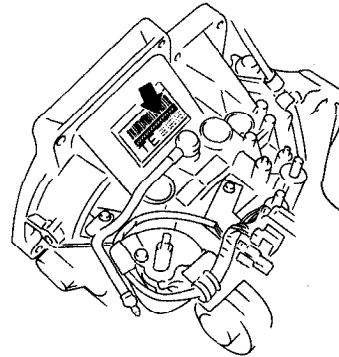

ENGINE MODEL AND NUMBER

BP ENGINE

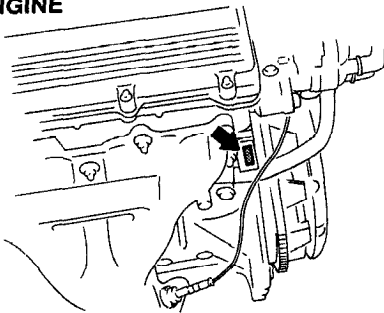

B6 ENGINE

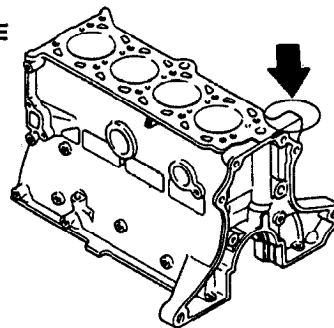

9MUGIX-015

UNITS

N·m (m·kg or cm·kg, ft·lb or in·lb)	Torque
rpm	Revolutions per minute
A	Ampere(s)
V	Volt(s)
Ω	Ohm(s) (resistance)
kPa (kg/cm ² , psi)	Pressure (usually positive)
mmHg (inHg)	Pressure (usually negative)
W	Watt
liters (US qt, Imp qt)	Volume
mm (in)	Length

89U0GX-006

ABBREVIATIONS

ABDC	After bottom dead center
A/C	Air conditioner
ACC	Accessories
ATX	Automatic transaxle
ATDC	After top dead center
ATF	Automatic transaxle fluid
BBDC	Before bottom dead center
BTDC	Before top dead center
CPU	Central processing unit
DOHC	Double overhead camshaft
DRL	Daytime running lights
EC-AT	Electronically-controlled automatic transaxle

ECU	Engine control unit
EGI	Electronic gasoline injection
E/L	Electrical load
EX	Exhaust
GND	Ground
HLA	Hydraulic lash adjuster
IGN	Ignition
IN	Intake
INT	Intermittent
ISC	Idle speed control
LH	Left hand
M	Motor
MIL	Malfunction indicator lamp
M/S	Manual steering
MTX	Manual transaxle
OD	Overdrive
OFF	Switch off
ON	Switch on
PCV	Positive crankcase ventilation
PRC	Pressure regulator control
P/S	Power steering
RH	Right hand
SOHC	Single overhead camshaft
SST	Special service tool
SW	Switch
TNS	Tail number side
VICS	Variable inertia charging system

23UGIX-003

CAUTION

INSTALLATION OF MOBILE TWO-WAY RADIO SYSTEM

If a mobile two-way radio system is installed improperly or if a high-powered type is used, the EGI system and other systems may be affected.

When the vehicle is to be equipped with a mobile two-way radio, observe the following precautions:

1. Install the antenna at the farthest point from control units.
2. Install the antenna feeder as far as possible from the control unit harnesses (**at least 30 cm [11.8 in]**).
3. Ensure that the antenna and feeder are properly adjusted.
4. Do not install a high-powered mobile two-way radio system.

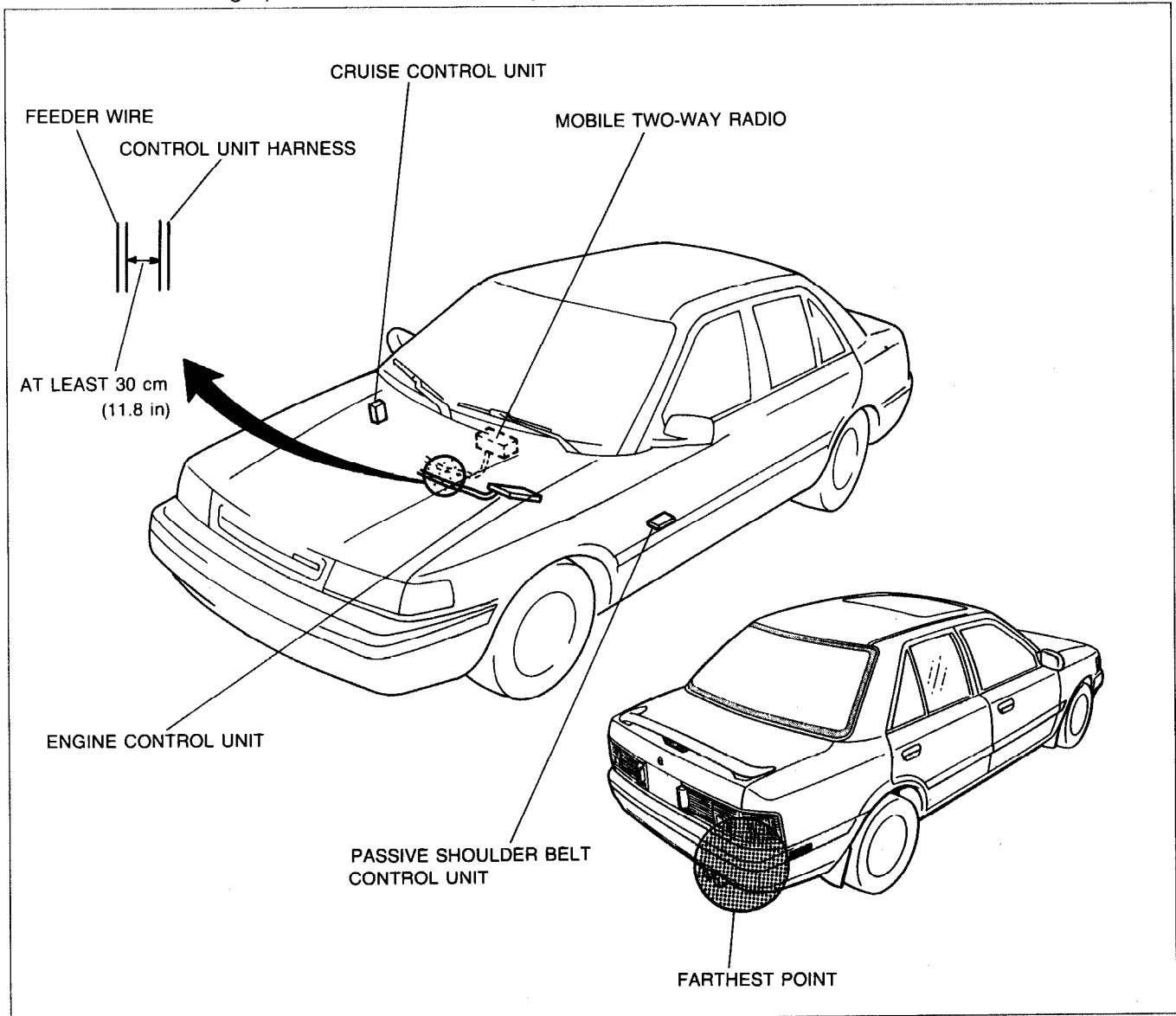

05UGIX-013

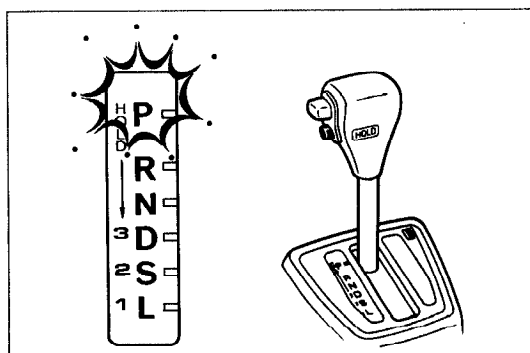

03UGIX-005

REMOVAL OF IGNITION KEY ON AUTOMATIC TRANSAXLE MODEL

The selector lever must be in P (PARK) to turn the ignition key to the OFF position. If the switch seems to be off but the key cannot be removed, the switch may still be in the ACC position, or the selector lever may not be in P (PARK). Shift the selector lever to P (PARK), and turn the ignition key to the LOCK position. The key should now be free for removal.

ELECTRICAL TROUBLESHOOTING TOOLS**Test Light**

The test light, as shown in the figure, uses a 12V bulb. The two lead wires should be connected to probes. The test light is used for simple voltage checks and for checking for short circuits.

Caution

- When checking the control unit, never use a bulb over 3.4W.

Jumper Wire

The jumper wire is used for testing by shorting across switch terminals and ground connections.

Caution

- Do not connect a jumper wire from the power source line to a body ground; this may cause burning or other damage to harnesses or electronic components.

Voltmeter

The DC voltmeter is used to measure of circuit voltage. A voltmeter with a range of 15V or more is used by connecting the positive (+) probe (red lead wire) to the point where voltage is to be measured and the negative (-) probe (black lead wire) to a body ground.

Diagnosis Connector

Insert the probe into the service hole when connecting a jumper wire to the diagnosis connector.

Caution

- Do not insert the jumper wire probe into the diagnosis connector terminal, which may damage the terminal.

Ohmmeter

The ohmmeter is used to measure the resistance between two points in a circuit and also to check for continuity and diagnosis of short circuits.

Caution

- Do not attempt to connect the ohmmeter to any circuit to which voltage is applied; this may burn or otherwise damage the ohmmeter.

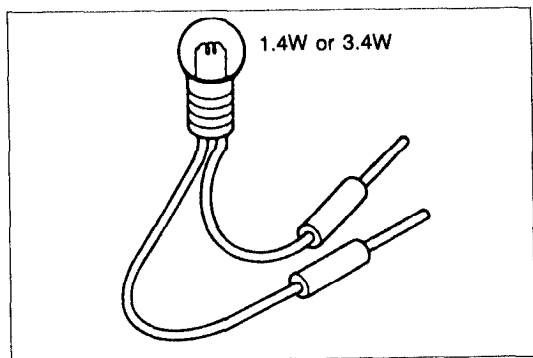

9MUGIX-019

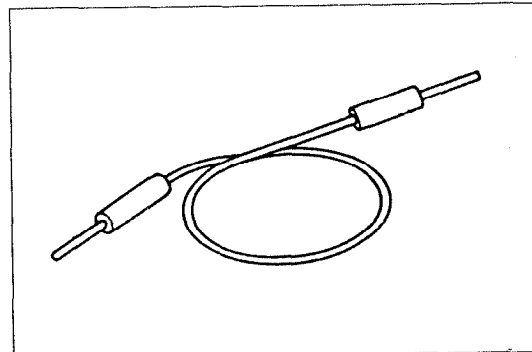

9MUGIX-020

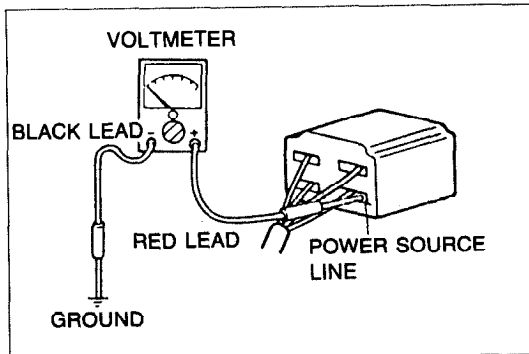

9MUGIX-021

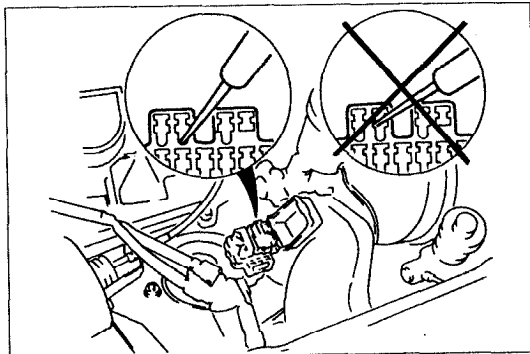

05UGIX-021

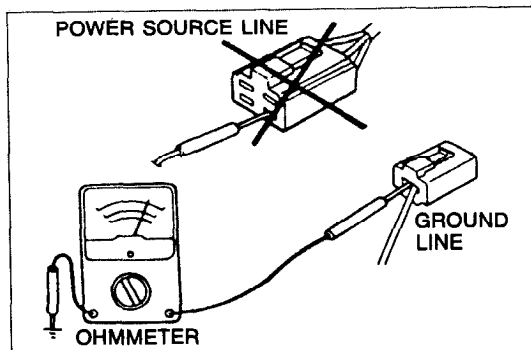

9MUGIX-045

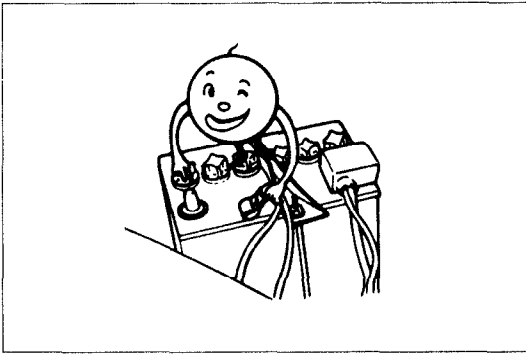

9MUGIX-022

CAUTION WITH ELECTRICAL PARTS

Battery Cable

Before disconnecting connectors or replacing electrical parts, disconnect the negative battery cable.

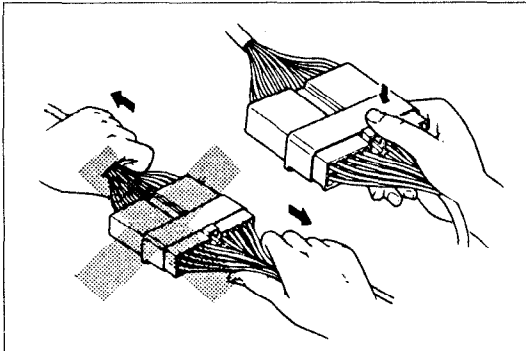

9MUGIX-023

Connectors

Removal of connector

Never pull on the wiring harness when disconnecting connectors.

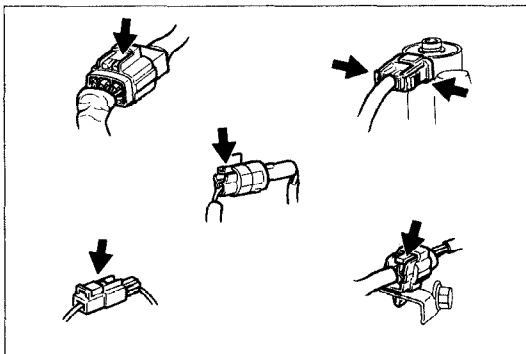

9MUGIX-024

Connectors can be removed by pressing or pulling the lock lever as shown.

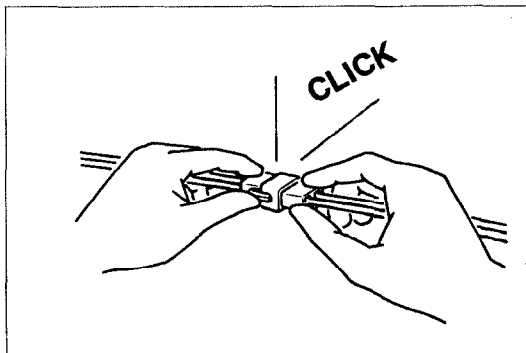

9MUGIX-025

Locking of connector

When locking connectors, make sure to listen for a click that will indicate they are securely locked.

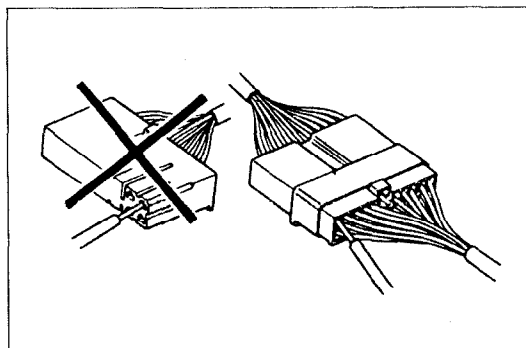

03UGIX-011

Inspection

1. When a tester is used to check for continuity or to measure voltage, insert the tester probe from the wire harness side.

2. Check the terminals of waterproof connectors from the connector side, as they cannot be accessed from the wire harness side.

Caution

- Use fine wire to prevent damage to the terminal.
- Do not damage the terminal when inserting the tester lead.

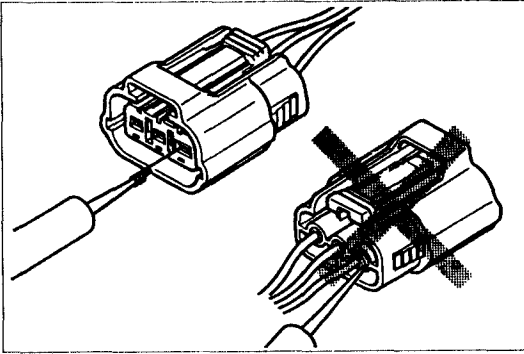

05UGIX-028

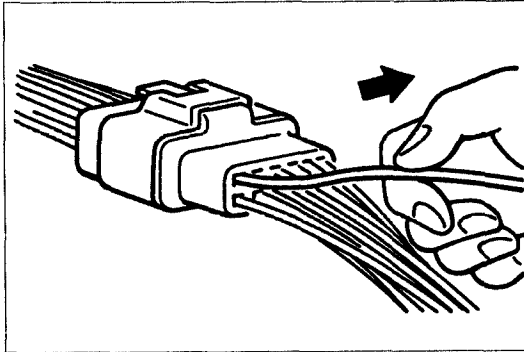

9MUGIX-027

Terminals

Inspection

Pull lightly on individual wires to check that they are secured in the terminal.

Replacement of terminals

Use the appropriate tools to remove the terminal as shown. When installing the terminal, be sure to insert it until it locks securely.

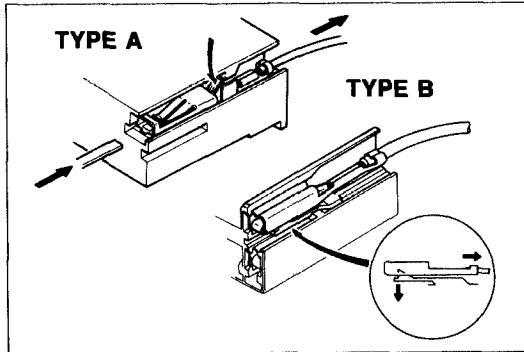

9MUGIX-028

< Female >

Insert a thin piece of metal from the terminal side of the connector, and then, with the terminal locking tab pressed down, pull the terminal out from the connector.

< Male >

Same as the female type.

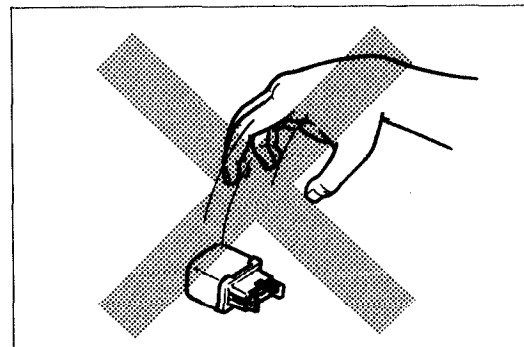
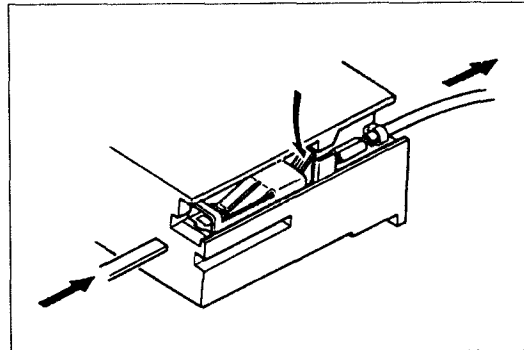

9MUGIX-030

Sensors, Switches, and Relays

Handle sensors, switches, and relays carefully. Do not drop them or strike them against other parts.