

---

# TABLE OF CONTENTS

<b>GENERAL INFORMATION</b>	<b>1</b>
<b>SPECIFICATIONS</b>	<b>2</b>
<b>PERIODIC CHECKS AND ADJUSTMENTS</b>	<b>3</b>
<b>CHASSIS</b>	<b>4</b>
<b>ENGINE</b>	<b>5</b>
<b>COOLING SYSTEM</b>	<b>6</b>
<b>FUEL SYSTEM</b>	<b>7</b>
<b>ELECTRICAL SYSTEM</b>	<b>8</b>
<b>TROUBLESHOOTING</b>	<b>9</b>



---

## GENERAL INFORMATION

<b>IDENTIFICATION</b> .....	1-1
VEHICLE IDENTIFICATION NUMBER.....	1-1
MODEL LABEL .....	1-1
<b>FEATURES</b> .....	1-2
FI SYSTEM.....	1-3
<b>IMPORTANT INFORMATION</b> .....	1-12
PREPARATION FOR REMOVAL AND DISASSEMBLY .....	1-12
REPLACEMENT PARTS.....	1-12
GASKETS, OIL SEALS AND O-RINGS.....	1-12
LOCK WASHERS/PLATES AND COTTER PINS .....	1-12
BEARINGS AND OIL SEALS .....	1-13
CIRCLIPS .....	1-13
<b>CHECKING THE CONNECTIONS</b> .....	1-14
<b>SPECIAL TOOLS</b> .....	1-15

EAS20130

## IDENTIFICATION

EAS20140

### VEHICLE IDENTIFICATION NUMBER

The vehicle identification number "1" is stamped into the right side of the steering head pipe.

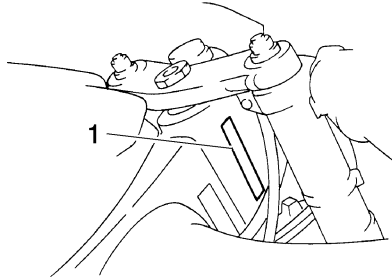

EAS20150

### MODEL LABEL

The model label "1" is affixed to the frame. This information will be needed to order spare parts.

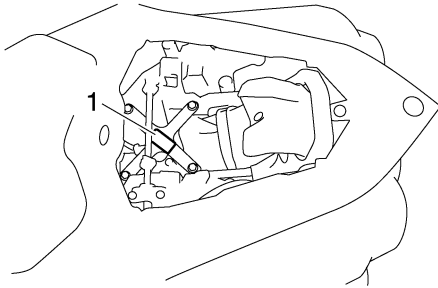

EAS20170

## FEATURES

### OUTLINE OF THE FI SYSTEM

The main function of a fuel supply system is to provide fuel to the combustion chamber at the optimum air-fuel ratio in accordance with the engine operating conditions and the atmospheric temperature. In the conventional carburetor system, the air-fuel ratio of the mixture that is supplied to the combustion chamber is created by the volume of the intake air and the fuel that is metered by the jet used in the respective carburetor.

Despite the same volume of intake air, the fuel volume requirement varies by the engine operating conditions, such as acceleration, deceleration, or operating under a heavy load. Carburetors that meter the fuel through the use of jets have been provided with various auxiliary devices, so that an optimum air-fuel ratio can be achieved to accommodate the constant changes in the operating conditions of the engine.

As the requirements for the engine to deliver more performance and cleaner exhaust gases increase, it becomes necessary to control the air-fuel ratio in a more precise and finely tuned manner. To accommodate this need, this model has adopted an electronically controlled fuel injection (FI) system, in place of the conventional carburetor system. This system can achieve an optimum air-fuel ratio required by the engine at all times by using a microprocessor that regulates the fuel injection volume according to the engine operating conditions detected by various sensors. The adoption of the FI system has resulted in a highly precise fuel supply, improved engine response, better fuel economy, and reduced exhaust emissions.

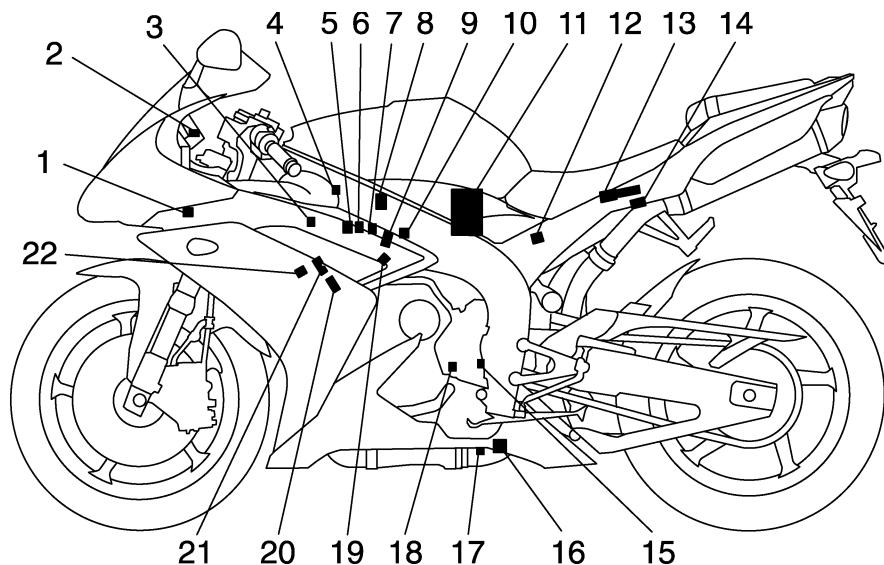

- |   |                                    |
|---|------------------------------------|
| 1. Intake air temperature sensor                        | 14. Starting circuit cut-off relay |
| 2. Engine trouble warning light                         | 15. Speed sensor                   |
| 3. Air induction system solenoid                        | 16. EXUP servo motor               |
| 4. Atmospheric pressure sensor                          | 17. O <sub>2</sub> sensor          |
| 5. Throttle position sensor (for throttle cable pulley) | 18. Crankshaft position sensor     |
| 6. Throttle servo motor                                 | 19. Coolant temperature sensor     |
| 7. Throttle position sensor (for throttle valves)       | 20. Spark plug                     |
| 8. Intake funnel servo motor                            | 21. Ignition coil                  |
| 9. Injector   | 22. Cylinder identification sensor |
| 10. Intake air pressure sensor                          |                                    |
| 11. Fuel pump   |                                    |
| 12. Lean angle sensor                                   |                                    |
| 13. ECU (engine control unit)                           |                                    |

EAS4C81010

## FI SYSTEM

The fuel pump delivers fuel to the fuel injector via the fuel filter. The pressure regulator maintains the fuel pressure that is applied to the fuel injector at only 324 kPa (3.24 kg/cm<sup>2</sup>, 46.1 psi). Accordingly, when the energizing signal from the ECU energizes the fuel injector, the fuel passage opens, causing the fuel to be injected into the intake manifold only during the time the passage remain open.

Therefore, the longer the length of time the fuel injector is energized (injection duration), the greater the volume of fuel that is supplied. Conversely, the shorter the length of time the fuel injector is energized (injection duration), the lesser the volume of fuel that is supplied.

The injection duration and the injection timing are controlled by the ECU. Signals that are input from the throttle position sensor (for throttle valves), throttle position sensor (for throttle cable pulley), crankshaft position sensor, intake air pressure sensor, intake air temperature sensor, coolant temperature sensor, atmospheric pressure sensor, cylinder identification sensor, lean angle sensor, speed sensor and O<sub>2</sub> sensor enable the ECU to determine the injection duration. The injection timing is determined through the signals from the crankshaft position sensor. As a result, the volume of fuel that is required by the engine can be supplied at all times in accordance with the driving conditions.

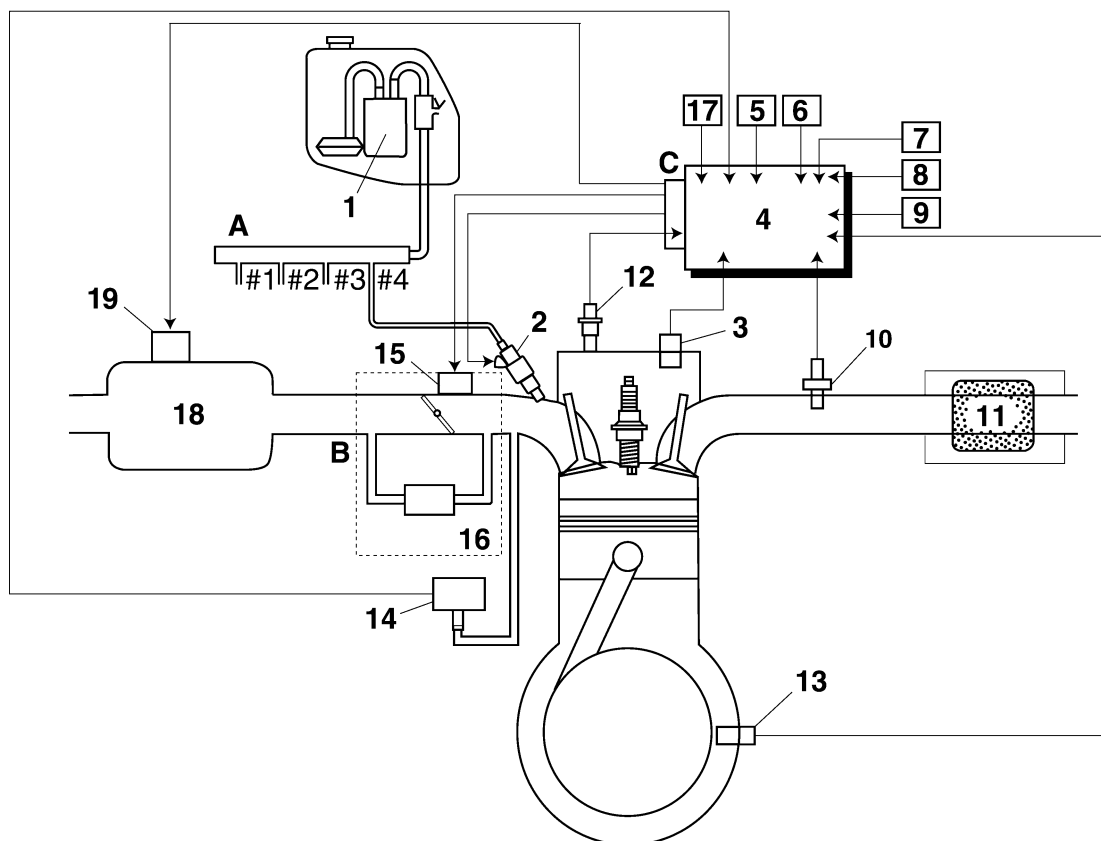

- |   |                                 |
|---|---------------------------------|
| 1. Fuel pump  | 12. Coolant temperature sensor  |
| 2. Injector   | 13. Crankshaft position sensor  |
| 3. Cylinder identification sensor                       | 14. Intake air pressure sensor  |
| 4. ECU (engine control unit)                            | 15. Throttle servo motor        |
| 5. Throttle position sensor (for throttle valves)       | 16. Throttle body               |
| 6. Throttle position sensor (for throttle cable pulley) | 17. Atmospheric pressure sensor |
| 7. Speed sensor   | 18. Air filter case             |
| 8. Intake air temperature sensor                        | 19. Intake funnel servo motor   |
| 9. Lean angle sensor                                    | A. Fuel system                  |
| 10. O <sub>2</sub> sensor                               | B. Air system                   |
| 11. Catalytic converter                                 | C. Control system               |

EAS4C81011

## YCC-T (Yamaha Chip Controlled Throttle) YCC-I (Yamaha Chip Controlled Intake)

### Mechanism characteristics

Yamaha developed the YCC-T and YCC-I system employing the most advanced electronic control technologies. Electronic control throttle systems have been used on automobiles, but Yamaha has developed a faster, more compact system specifically for the needs of a sports motorcycle. The Yamaha-developed system has a high-speed calculating capacity that produces computations of running conditions every 1/1000th of a second.

The YCC-T system is designed to respond to the throttle action of the rider by having the ECU instantaneously calculate the ideal throttle valve opening and generate signals to operate the motor-driven throttle valves and thus actively control the intake air volume.

The ECU contains three CPUs with a capacity about five times that of conventional units, making it possible for the system to respond extremely quickly to the slightest adjustments made by the rider. In particular, optimized control of the throttle valve opening provides the optimum volume of intake air for easy-to-use torque, even in a high-revving engine.

The YCC-I system calculates the value from the engine revolution number and throttle opening rate, activates the intake air funnel with the electronic control motor drive to control the intake pipe length in order to gain the high power output in all revolution ranges from low speeds to high speeds.

### Aims and advantages of using YCC-T system

- Increased engine power  
By shortening the air intake path, higher engine speed is possible → Increased engine power.
- Improved driveability  
Air intake volume is controlled according to the operating conditions → Improved throttle response to meet engine requirement.  
Driving force is controlled at the optimal level according to the transmission gear position and engine speed → Improved throttle control.
- Engine braking control  
Due to the throttle control, optimal engine braking is made possible.
- Simplified idle speed control (ISC) mechanism  
The bypass mechanism and ISC actuator are eliminated → A simple mechanism is used to maintain a steady idle speed.
- Reduced weight  
Compared to using a sub-throttle mechanism, weight is reduced.

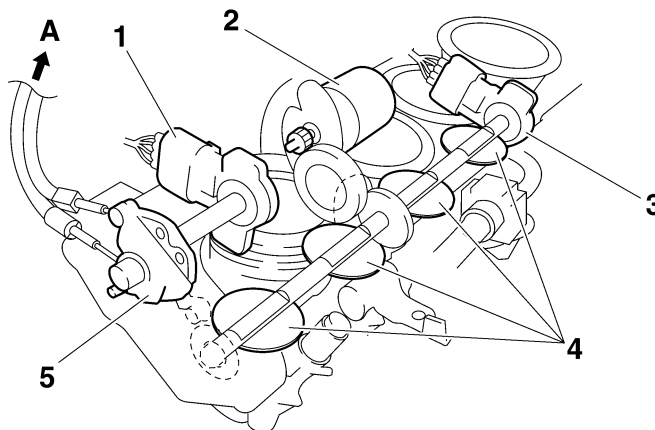

1. Throttle position sensor (for throttle cable pulley)
2. Throttle servo motor
3. Throttle position sensor (for throttle valves)
4. Throttle valves
5. Throttle cable pulley with linkage guard

A. To throttle grip

## Aims and advantages of using YCC-I system

- Improvement of the engine power characteristics

The high power design in all ranges is now provided by having both two features of the short intake function to ensure the power at the high speed revolution of engine, and the long intake function to ensure the power in the practical use range.

- Intake pipe length switching control using the motor

The intake pipe length switching operation in a minute time is now available by means of the motor drive using the electronic control. The smooth power characteristic is provided, which does not let an operator feel the switching action by the optimization of its switching revolution number and the most suitable application of engine at the time of changing the revolution.

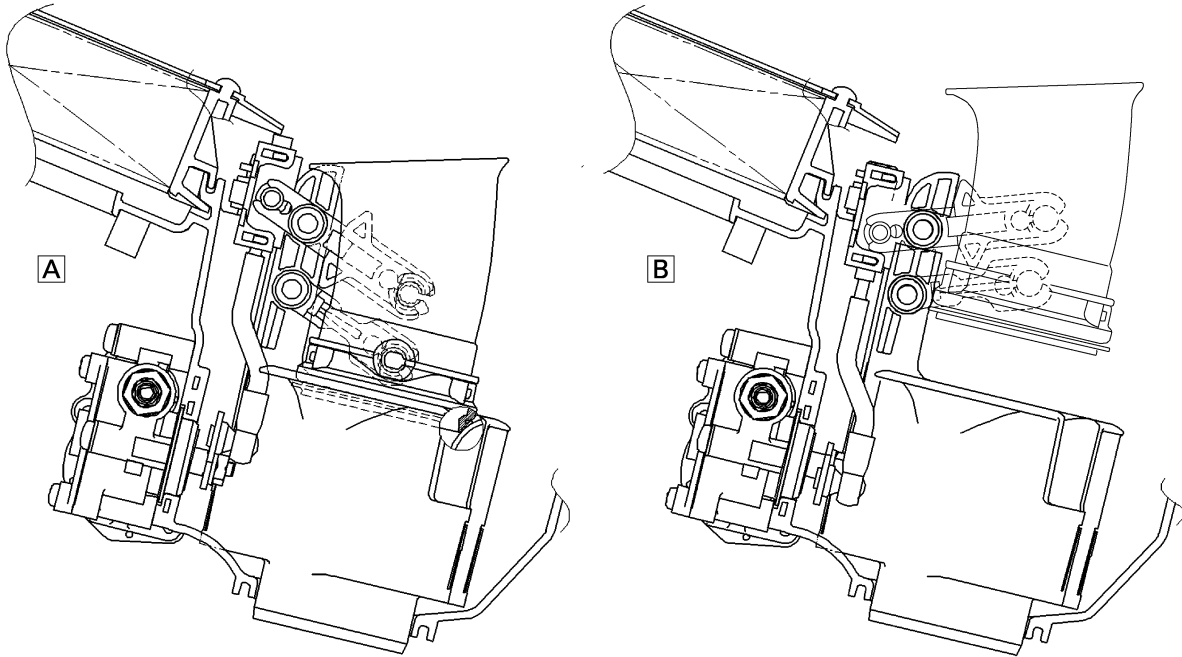

- A. Down position (long intake)  
(Low rpm to Mid rpm)
- B. Up position (short intake)  
(High rpm)



## YCC-T/YCC-I system outline

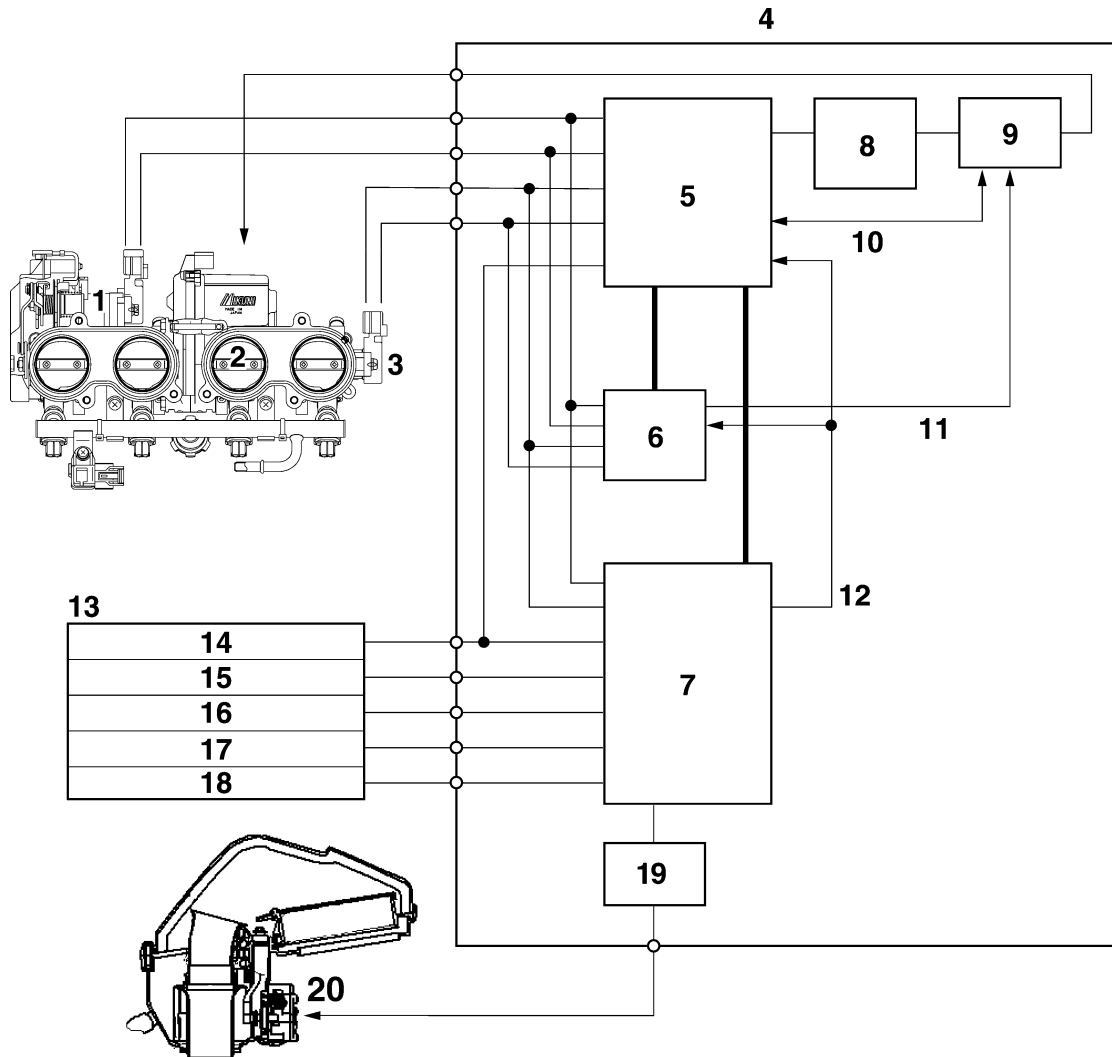

1. Throttle position sensor (for throttle cable pulley)
2. Throttle servo motor
3. Throttle position sensor (for throttle valves)
4. ECU (engine control unit)
5. ETV main CPU (32 bit)
6. ETV sub CPU (16 bit)
7. FI CPU (32 bit)
8. Throttle servo motor driver
9. Throttle servo motor driver operation sensing/shut off circuit
10. Throttle servo motor driver operation sensing feedback/emergency stop
11. Emergency stop
12. Engine revolution (pulse signal)
13. Sensor input
14. Neutral switch
15. Crankshaft position sensor
16. Speed sensor
17. Coolant temperature sensor
18. Atmospheric pressure sensor

19. Intake funnel servo motor driver
20. Intake funnel servo motor

## YCC-T/YCC-I control outline

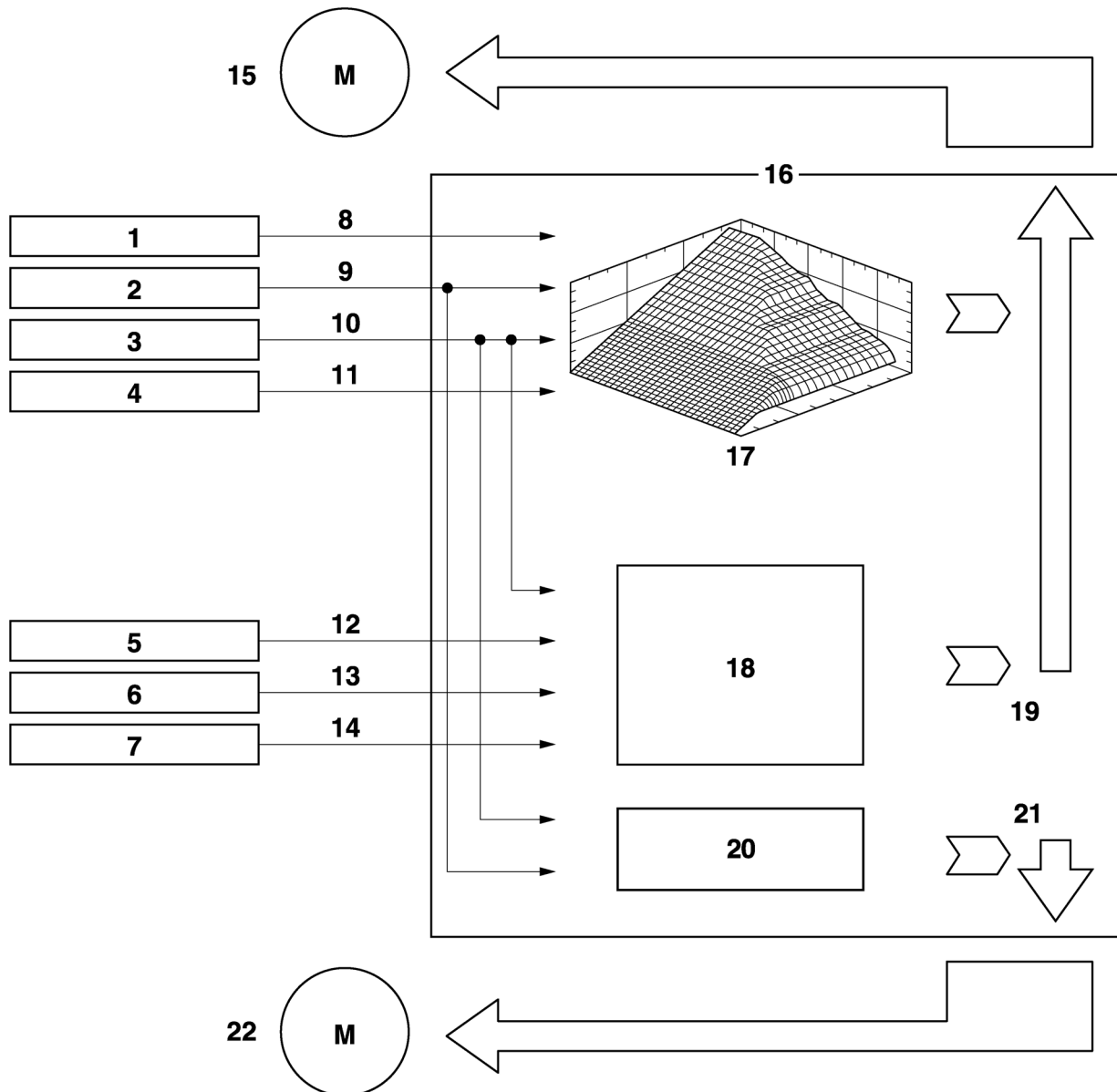

1. Throttle position sensor (for throttle cable pulley)
2. Throttle position sensor (for throttle valves)
3. Crankshaft position sensor
4. Speed sensor
5. Coolant temperature sensor
6. Neutral switch
7. Atmospheric pressure sensor
8. Accelerator position (two signals)
9. Throttle position (two signals)
10. Engine revolution
11. Vehicle speed
12. Coolant temperature
13. Neutral/In gear
14. Atmospheric pressure

15. Throttle servo motor
16. ECU (engine control unit)
17. Base map
18. Idle speed control
19. Calculated throttle valve opening angle
20. Base map
21. Air funnel position (Calculation value)
22. Intake funnel servo motor

EAS4C81024

## INSTRUMENT FUNCTIONS

### Multi-function meter unit

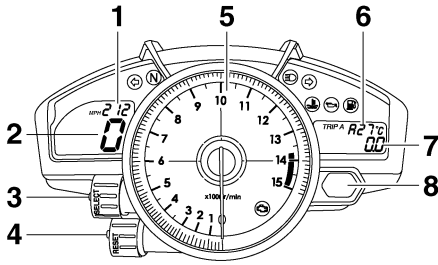

1. Clock
2. Speedometer
3. "SELECT" button
4. "RESET" button
5. Tachometer
6. Coolant temperature display/air intake temperature display
7. Odometer/tripmeters/fuel reserve tripmeter/ stopwatch
8. Shift timing indicator light

EWA4C81008

### **WARNING**

**Be sure to stop the vehicle before making any setting changes to the multi-function meter unit.**

The multi-function meter unit is equipped with the following:

- a speedometer (which shows the riding speed)
- a tachometer (which shows engine speed)
- an odometer (which shows the total distance traveled)
- two tripmeters (which show the distance traveled since they were last set to zero)
- a fuel reserve tripmeter (which shows the distance traveled since the fuel level warning light came on)
- a clock
- a coolant temperature display
- an air intake temperature display
- a self-diagnosis device
- a display brightness and shift timing indicator light control mode

### **NOTE:**

- Be sure to turn the key to "ON" before using the "SELECT" and "RESET" buttons.

- To switch the speedometer and odometer/ tripmeter displays between kilometers and miles, press the "SELECT" button for at least one second.

### Tachometer

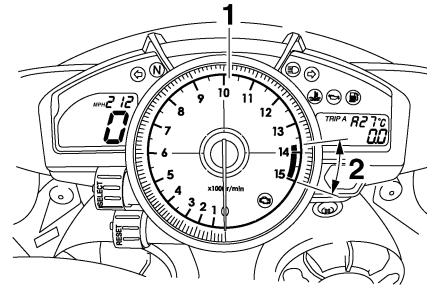

1. Tachometer
2. Tachometer red zone

The electric tachometer allows the rider to monitor the engine speed and keep it within the ideal power range.

When the key is turned to "ON", the tachometer needle will sweep once across the r/min range and then return to zero r/min in order to test the electrical circuit.

ECA4C81017

### **CAUTION:**

**Do not operate the engine in the tachometer red zone.**

**Red zone: 13750 r/min and above**

### Clock mode

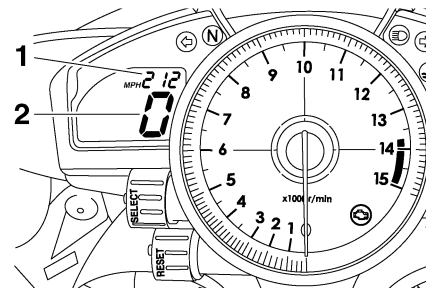

1. Clock

Turn the key to "ON".

To set the clock

1. Push the "SELECT" button and "RESET" button together for at least two seconds.
2. When the hour digits start flashing, push the "RESET" button to set the hours.
3. Push the "SELECT" button, and the minute digits will start flashing.

4. Push the “RESET” button to set the minutes.
5. Push the “SELECT” button and then release it to start the clock.

## Odometer, tripmeter, and stopwatch modes

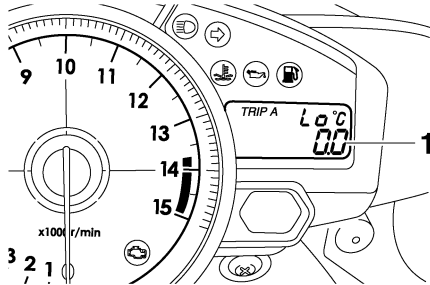

1. Odometer/tripmeter/fuel reserve tripmeter

Push the “SELECT” button to switch the display between the odometer mode “ODO” and the tripmeter modes “TRIP A” and “TRIP B” and the stopwatch mode in the following order: TRIP A → TRIP B → ODO → Stopwatch → TRIP A

If the fuel level warning light comes on, the odometer display will automatically change to the fuel reserve tripmeter mode “F-TRIP” and start counting the distance traveled from that point. In that case, push the “SELECT” button to switch the display between the various tripmeter, odometer, and stopwatch modes in the following order:

F-TRIP → Stopwatch → TRIP A → TRIP B → ODO → F-TRIP

To reset a tripmeter, select it by pushing the “SELECT” button, and then push the “RESET” button for at least one second. If you do not reset the fuel reserve tripmeter manually, it will reset itself automatically and the display will return to the prior mode after refueling and traveling 5 km (3 mi).

## Stopwatch mode



To change the display to the stopwatch mode, select it by pushing the “SELECT” button. (The stopwatch digits will start flashing.) Release the “SELECT” button, and then push it again for a few seconds until the stopwatch digits stop flashing.

### Standard measurement

1. Push the “RESET” button to start the stopwatch.
2. Push the “SELECT” button to stop the stopwatch.

3. Push the “SELECT” button again to reset the stopwatch.

### Split-time measurement

1. Push the “RESET” button to start the stopwatch.
2. Push the “RESET” button or start switch “” to measure split-times. (The colon “:” will start flashing.)
3. Push the “RESET” button or start switch “” to measure split-times. (The colon “:” will start flashing.)
4. Push the “SELECT” button to reset the stopwatch.

### NOTE:

To change the display back to the prior mode, push the “SELECT” button for a few seconds.

## Coolant temperature display

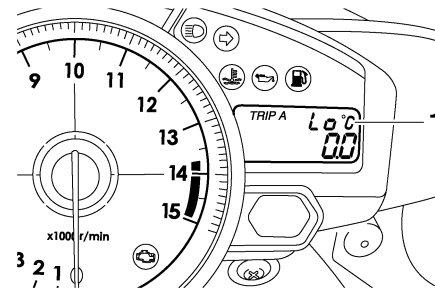

1. Coolant temperature display

The coolant temperature display indicates the temperature of the coolant.

Push the “RESET” button to switch the coolant temperature display to the air intake temperature display.

### NOTE:

When the coolant temperature display is selected, “C” is displayed for one second, and then the coolant temperature is displayed.

ECA4C81018

### CAUTION:

**Do not operate the engine if it is overheated.**

## Air intake temperature display

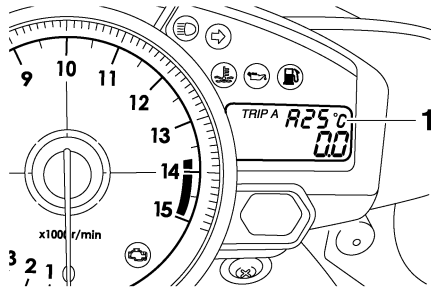

1. Air intake temperature display

The air intake temperature display indicates the temperature of the air drawn into the air filter case. Push the “RESET” button to switch the coolant temperature display to the air intake temperature display.

### NOTE:

- Even if the air intake temperature is set to be displayed, the coolant temperature warning light comes on when the engine overheats.
- When the key is turned to “ON”, the coolant temperature is automatically displayed, even if the air intake temperature was displayed prior to turning the key to “OFF”.
- When the air intake temperature display is selected, “A” is displayed before the temperature.

## Self-diagnosis device

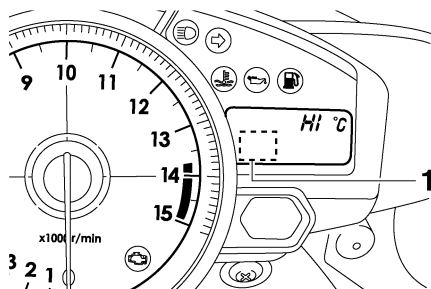

1. Error code display

This model is equipped with a self-diagnosis device for various electrical circuits. If any of those circuits are defective, the engine trouble warning light will come on, and then the display will indicate a two-digit error code.

## Display brightness and shift timing indicator light control mode

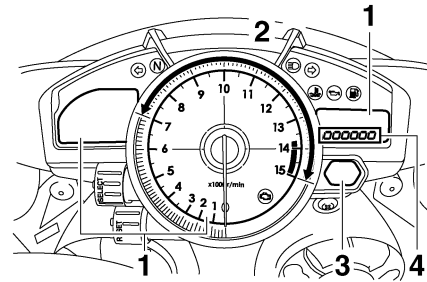

1. Display brightness
2. Shift timing indicator light activation/deactivation
3. Shift timing indicator light
4. Brightness level

This mode cycles through five control functions, allowing you to make the following settings in the order listed below.

### Display brightness:

- This function allows you to adjust the brightness of the displays and tachometer to suit the outside lighting conditions.
- Shift timing indicator light activity: This function allows you to choose whether or not the indicator light should be activated and whether it should flash or stay on when activated.
- Shift timing indicator light activation: This function allows you to select the engine speed at which the indicator light will be activated.
- Shift timing indicator light deactivation: This function allows you to select the engine speed at which the indicator light will be deactivated.
- Shift timing indicator light brightness: This function allows you to adjust the brightness of the indicator light to suit your preference.

### NOTE:

In this mode, the right display shows the current setting for each function (except the shift timing indicator light activity function).

To adjust the brightness of the multifunction meter displays and tachometer

1. Turn the key to “OFF”.
2. Push and hold the “SELECT” button.
3. Turn the key to “ON”, and then release the “SELECT” button after five seconds.

4. Push the “RESET” button to select the desired brightness level.
5. Push the “SELECT” button to confirm the selected brightness level. The control mode changes to the shift timing indicator light activity function.

To set the shift timing indicator light activity function

1. Push the “RESET” button to select one of the following indicator light activity settings:
  - The indicator light will stay on when activated. (This setting is selected when the indicator light stays on.)
  - The indicator light will flash when activated. (This setting is selected when the indicator light flashes four times per second.)
  - The indicator light is deactivated; in other words, it will not come on or flash. (This setting is selected when the indicator light flashes once every two seconds.)
2. Push the “SELECT” button to confirm the selected indicator light activity. The control mode changes to the shift timing indicator light activation function.ry two seconds.)

To set the shift timing indicator light activation function

**NOTE:** \_\_\_\_\_

The shift timing indicator light activation function can be set between 7000 r/min and 15000 r/min. From 7000 r/min to 12000 r/min, the indicator light can be set in increments of 500 r/min. From 12000 r/min to 15000 r/min, the indicator light can be set in increments of 200 r/min.

1. Push the “RESET” button to select the desired engine speed for activating the indicator light.
2. Push the “SELECT” button to confirm the selected engine speed. The control mode changes to the shift timing indicator light deactivation function.

To set the shift timing indicator light deactivation function

**NOTE:** \_\_\_\_\_

- The shift timing indicator light deactivation function can be set between 7000 r/min and 15000 r/min. From 7000 r/min to 12000 r/min, the indicator light can be set in increments of 500 r/min. From 12000 r/min to 15000 r/min, the indicator light can be set in increments of 200 r/min.

- Be sure to set the deactivation function to a higher engine speed than for the activation function, otherwise the shift timing indicator light will remain deactivated.

1. Push the “RESET” button to select the desired engine speed for deactivating the indicator light.
2. Push the “SELECT” button to confirm the selected engine speed. The control mode changes to the shift timing indicator light brightness function.

To adjust the shift timing indicator light brightness

1. Push the “RESET” button to select the desired indicator light brightness level.
2. Push the “SELECT” button to confirm the selected indicator light brightness level. The right display will return to the odometer or tripmeter mode.

EAS20180

## IMPORTANT INFORMATION

EAS20190

### PREPARATION FOR REMOVAL AND DISASSEMBLY

1. Before removal and disassembly, remove all dirt, mud, dust and foreign material.



2. Use only the proper tools and cleaning equipment. Refer to "SPECIAL TOOLS" on page 1-15.
3. When disassembling, always keep mated parts together. This includes gears, cylinders, pistons and other parts that have been "mated" through normal wear. Mated parts must always be reused or replaced as an assembly.

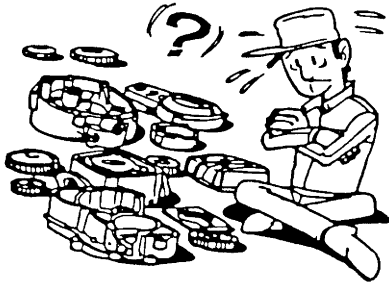

4. During disassembly, clean all of the parts and place them in trays in the order of disassembly. This will speed up assembly and allow for the correct installation of all parts.
5. Keep all parts away from any source of fire.

EAS20200

### REPLACEMENT PARTS

Use only genuine Yamaha parts for all replacements. Use oil and grease recommended by Yamaha for all lubrication jobs. Other brands may be similar in function and appearance, but inferior in quality.

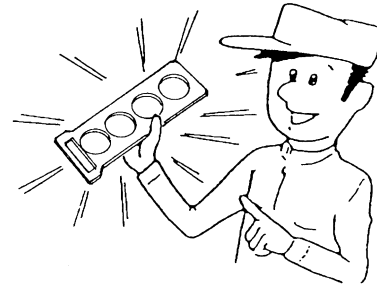

EAS20210

### GASKETS, OIL SEALS AND O-RINGS

1. When overhauling the engine, replace all gaskets, seals and O-rings. All gasket surfaces, oil seal lips and O-rings must be cleaned.
2. During reassembly, properly oil all mating parts and bearings and lubricate the oil seal lips with grease.

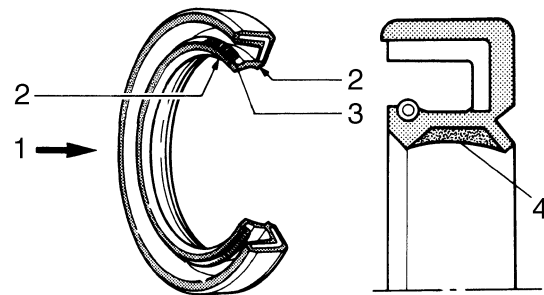

1. Oil
2. Lip
3. Spring
4. Grease

EAS20220

### LOCK WASHERS/PLATES AND COTTER PINS

After removal, replace all lock washers/plates "1" and cotter pins. After the bolt or nut has been tightened to specification, bend the lock tabs along a flat of the bolt or nut.

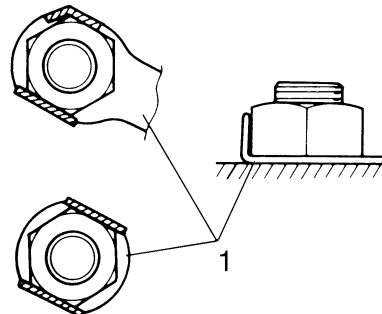

EAS20230

## BEARINGS AND OIL SEALS

Install bearings "1" and oil seals "2" so that the manufacturer's marks or numbers are visible. When installing oil seals, lubricate the oil seal lips with a light coat of lithium-soap-based grease. Oil bearings liberally when installing, if appropriate.

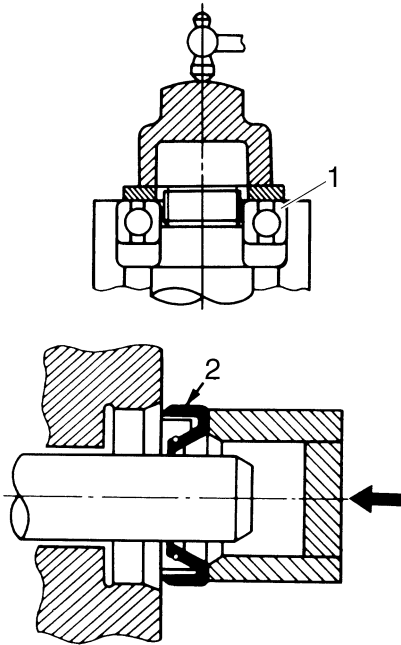

ECA13300

### CAUTION:

**Do not spin the bearing with compressed air because this will damage the bearing surfaces.**

EAS20240

## CIRCLIPS

Before reassembly, check all circlips carefully and replace damaged or distorted circlips. Always replace piston pin clips after one use. When installing a circlip "1", make sure the sharp-edged corner "2" is positioned opposite the thrust "3" that the circlip receives.

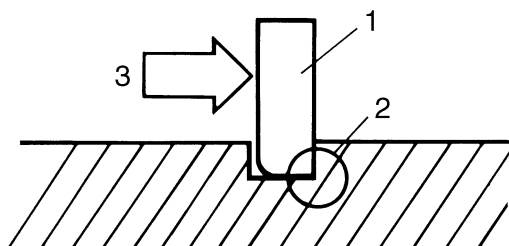



# CHECKING THE CONNECTIONS

EAS20250

## CHECKING THE CONNECTIONS

Check the leads, couplers, and connectors for stains, rust, moisture, etc.

1. Disconnect:

- Lead
- Coupler
- Connector

2. Check:

- Lead
- Coupler
- Connector

Moisture → Dry with an air blower.

Rust/stains → Connect and disconnect several times.

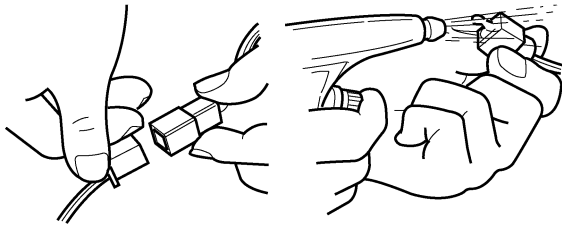

3. Check:

- All connections

Loose connection → Connect properly.

**NOTE:**

If the pin "1" on the terminal is flattened, bend it up.

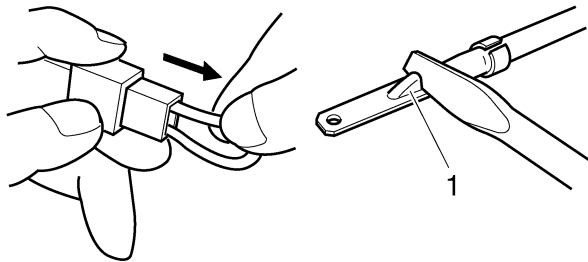

4. Connect:

- Lead
- Coupler
- Connector

**NOTE:**

Make sure all connections are tight.

5. Check:

- Continuity  
(with the pocket tester)



Pocket tester

90890-03112

Analog pocket tester

YU-03112-C

**NOTE:**

- If there is no continuity, clean the terminals.
- When checking the wire harness, perform steps (1) to (3).
- As a quick remedy, use a contact revitalizer available at most part stores.

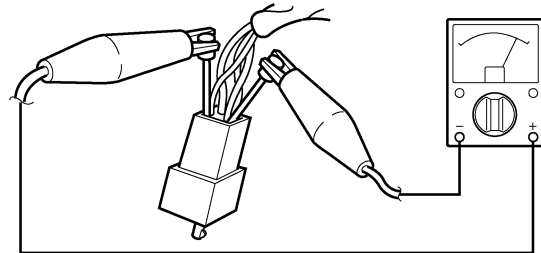
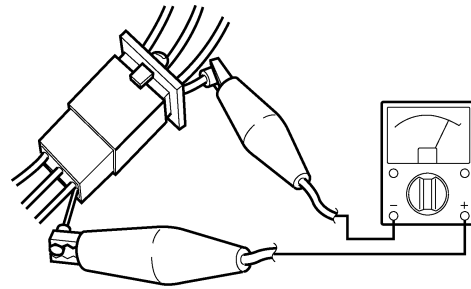

EAS20260

## SPECIAL TOOLS

The following special tools are necessary for complete and accurate tune-up and assembly. Use only the appropriate special tools as this will help prevent damage caused by the use of inappropriate tools or improvised techniques. Special tools, part numbers or both may differ depending on the country.

When placing an order, refer to the list provided below to avoid any mistakes.

**NOTE:**

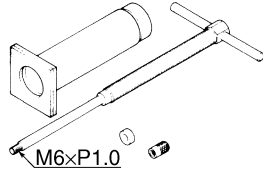
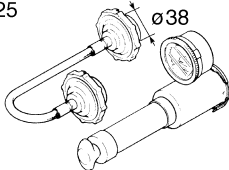
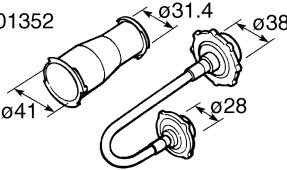
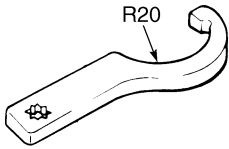
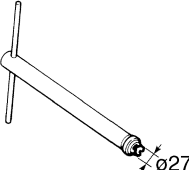
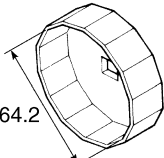

- For U.S.A. and Canada, use part number starting with “YM-”, “YU-”, or “ACC-”.
- For others, use part number starting with “90890-”.

Tool name/Tool No.	Illustration	Reference pages
Piston pin puller set 90890-01304 Piston pin puller YU-01304	90890-01304 	5-71
Radiator cap tester 90890-01325 Radiator pressure tester YU-24460-01	90890-01325 	6-3
Radiator cap tester adapter 90890-01352 Radiator pressure tester adapter YU-33984	90890-01352 	6-3
Steering nut wrench 90890-01403 Spanner wrench YU-33975		3-28, 4-60
Damper rod holder 90890-01423 Damping rod holder YM-01423		4-52, 4-53
Oil filter wrench 90890-01426 YU-38411		3-12

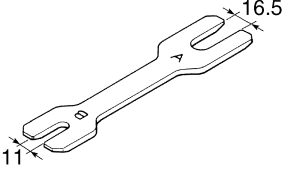
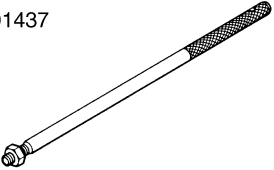
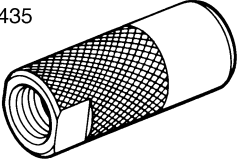
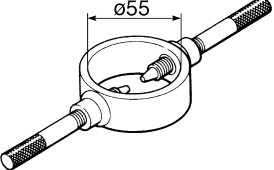
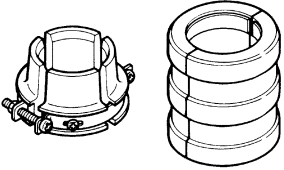
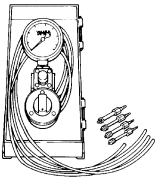
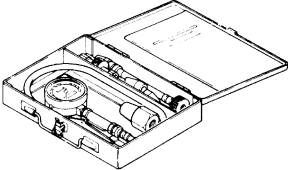
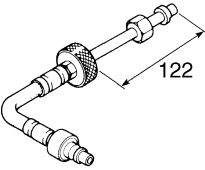

# SPECIAL TOOLS

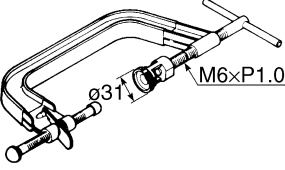
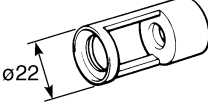
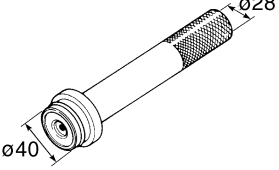
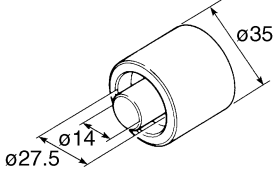
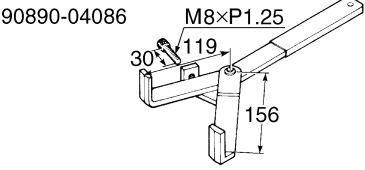
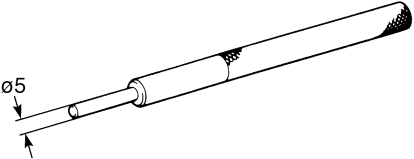
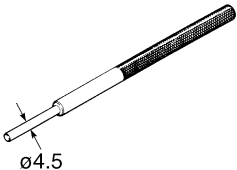
Tool name/Tool No.	Illustration	Reference pages
Rod holder 90890-01434 Damper rod holder double ended YM-01434		4-51, 4-56
Rod puller 90890-01437 Universal damping rod bleeding tool set YM-A8703	90890-01437 	4-55, 4-56
Rod puller attachment (M12) 90890-01435 Universal damping rod bleeding tool set YM-A8703	90890-01435 	4-55, 4-56
Fork spring compressor 90890-01441 YM-01441		4-51, 4-56
Fork seal driver 90890-01442 Adjustable fork seal driver (36–46 mm) YM-01442		4-54
Vacuum gauge 90890-03094 Carburetor synchronizer YU-44456	90890-03094 	3-7
Compression gauge 90890-03081 Engine compression tester YU-33223		3-10
Extension 90890-04136		3-10

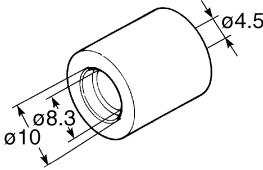
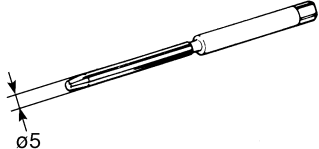
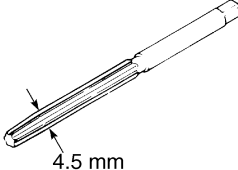
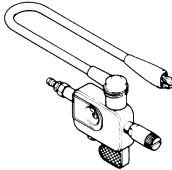
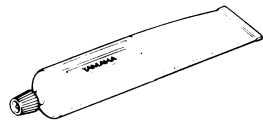
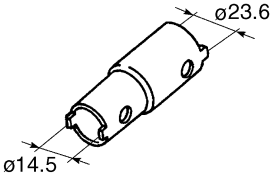
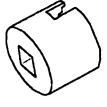

# SPECIAL TOOLS

Tool name/Tool No.	Illustration	Reference pages
Valve spring compressor 90890-04019 YM-04019		5-23, 5-29
Valve spring compressor attachment 90890-04108 Valve spring compressor adapter (22 mm) YM-04108		5-23, 5-29
Middle driven shaft bearing driver 90890-04058 Bearing driver (40 mm) YM-04058		6-11
Mechanical seal installer 90890-04078 Water pump seal installer YM-33221-A		6-11
Universal clutch holder 90890-04086 YM-91042		5-47, 5-51
Valve guide remover (ø5) 90890-04097 Valve guide remover (5.0 mm) YM-04097		5-25
Valve guide remover (ø4.5) 90890-04116 Valve guide remover (4.5 mm) YM-04116		5-25
Valve guide installer (ø5) 90890-04098 Valve guide installer (5.0 mm) YM-04098		5-25

# SPECIAL TOOLS

Tool name/Tool No.	Illustration	Reference pages
Valve guide installer (ø4.5) 90890-04117 Valve guide installer (4.5 mm) YM-04117		5-25
Valve guide reamer (ø5) 90890-04099 Valve guide reamer (5.0 mm) YM-04099		5-25
Valve guide reamer (ø4.5) 90890-04118 Valve guide reamer (4.5mm) YM-04118		5-25
Ignition checker 90890-06754 Opama pet-4000 spark checker YU-34487		8-84
Yamaha bond No.1215 (Three Bond No.1215) 90890-85505		5-67, 6-11
Pivot shaft wrench 90890-01471 Frame spanner socket YM-01471		5-7
Pivot shaft wrench adapter 90890-01476		5-7
Pocket tester 90890-03112 Analog pocket tester YU-03112-C		1-14, 5-41, 8-75, 8-76, 8-77, 8-80, 8-81, 8-82, 8-83, 8-84, 8-85, 8-86, 8-87, 8-88, 8-89, 8-90, 8-91, 8-92

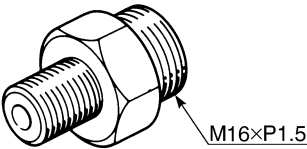
# SPECIAL TOOLS

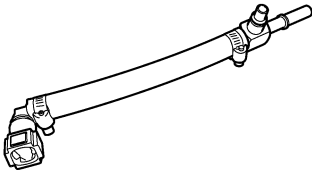
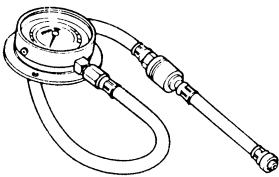
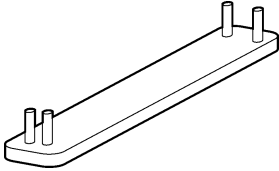
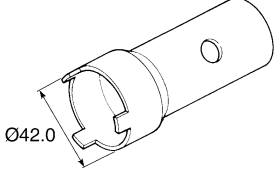
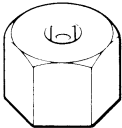
Tool name/Tool No.	Illustration	Reference pages
Oil pressure gauge adapter 90890-03139		3-13
Valve lapper 90890-04101 Valve lapping tool YM-A8998		3-5
Fuel pressure adapter 90890-03176 YM-03176		7-6
Pressure gauge 90890-03153 YU-03153		3-13, 7-6
Camshaft wrench 90890-04143 YM-04143		5-11, 5-16
Ring nut wrench 90890-01507 YM-01507		4-67, 4-69
Damper rod holder (22 mm) 90890-01365		4-68, 4-69

---

# SPECIFICATIONS

<b>GENERAL SPECIFICATIONS</b> .....	2-1
<b>ENGINE SPECIFICATIONS</b> .....	2-2
<b>CHASSIS SPECIFICATIONS</b> .....	2-8
<b>ELECTRICAL SPECIFICATIONS</b> .....	2-10
<b>TIGHTENING TORQUES</b> .....	2-12
GENERAL TIGHTENING TORQUE SPECIFICATIONS .....	2-12
ENGINE TIGHTENING TORQUES .....	2-13
CHASSIS TIGHTENING TORQUES .....	2-17
<b>LUBRICATION POINTS AND LUBRICANT TYPES</b> .....	2-20
ENGINE .....	2-20
CHASSIS .....	2-21
<b>LUBRICATION SYSTEM CHART AND DIAGRAMS</b> .....	2-23
ENGINE OIL LUBRICATION CHART .....	2-23
LUBRICATION DIAGRAMS .....	2-25
<b>COOLING SYSTEM DIAGRAMS</b> .....	2-35
<b>CABLE ROUTING</b> .....	2-39

# GENERAL SPECIFICATIONS

---

EAS20280

## GENERAL SPECIFICATIONS

---

### Model

Model	4C84 (U.S.A.) 4C85 (California)
-------	------------------------------------

---

### Dimensions

Overall length	2060 mm (81.1 in)
Overall width	720 mm (28.3 in)
Overall height	1110 mm (43.7 in)
Seat height	835 mm (32.9 in)
Wheelbase	1415 mm (55.7 in)
Ground clearance	135 mm (5.31 in)
Minimum turning radius	3400 mm (133.9 in)

---

### Weight

With oil and fuel	200 kg (441 lb)
Maximum load	195 kg (430 lb)



# ENGINE SPECIFICATIONS

EAS20290

## ENGINE SPECIFICATIONS

### Engine

Engine type	Liquid cooled 4-stroke, DOHC
Displacement	998.0 cm <sup>3</sup>
Cylinder arrangement	Forward-inclined parallel 4-cylinder
Bore × stroke	77.0 × 53.6 mm (3.03 × 2.11 in)
Compression ratio	12.70 :1
Standard compression pressure (at sea level)	1480 kPa/350 r/min (210.5 psi/350 r/min) (14.8 kgf/cm <sup>2</sup> /350 r/min)
Starting system	Electric starter

### Fuel

Recommended fuel	Premium unleaded gasoline only
Fuel tank capacity	18.0 L (4.76 US gal) (3.96 Imp.gal)
Fuel reserve amount	3.2 L (0.85 US gal) (0.70 Imp.gal)

### Engine oil

Lubrication system	Wet sump
Type	YAMALUBE 4, SAE 10W30 or SAE 20W40
Recommended engine oil grade	API service, SG type or higher, JASO standard MA

### Engine oil quantity

Total amount	3.83 L (4.05 US qt) (3.37 Imp.qt)
Without oil filter cartridge replacement	2.90 L (3.07 US qt) (2.55 Imp.qt)
With oil filter cartridge replacement	3.10 L (3.28 US qt) (2.73 Imp.qt)

### Oil filter

Oil filter type	Formed
-----------------	--------

### Oil pump

Oil pump type	Trochoid
Inner-rotor-to-outer-rotor-tip clearance	0.010–0.100 mm (0.0004–0.0039 in)
Limit	0.18 mm (0.0071 in)
Outer-rotor-to-oil-pump-housing clearance	0.090–0.190 mm (0.0035–0.0074 in)
Limit	0.26 mm (0.0102 in)
Oil-pump-housing-to-inner-and-outer-rotor clearance	0.06–0.13 mm (0.0024–0.0051 in)
Limit	0.20 mm (0.0079 in)
Bypass valve opening pressure	80.0–120.0 kPa (11.6–17.4 psi) (0.80–1.20 kgf/cm <sup>2</sup> )
Relief valve operating pressure	600.0–680.0 kPa (87.0–98.6 psi) (6.00–6.80 kgf/cm <sup>2</sup> )

### Cooling system

Radiator capacity (including all routes)	2.76 L (2.92 US qt) (2.43 Imp.qt)
Coolant reservoir capacity (up to the maximum level mark)	0.25 L (0.26 US qt) (0.22 Imp.qt)
Radiator cap opening pressure	108–137 kPa (15.4–19.5 psi) (1.08–1.37 kgf/cm <sup>2</sup> )

### Radiator core

Width	374.0 mm (14.72 in)
Height	257.8 mm (10.15 in)
Depth	24.0 mm (0.94 in)

### Water pump

Water pump type	Single suction centrifugal pump
Reduction ratio	65/43 × 25/32 (1.181)

### Spark plug (s)

# ENGINE SPECIFICATIONS

Manufacturer/model	NGK/CR9EK
Spark plug gap	0.6–0.7 mm (0.024–0.028 in)

## Cylinder head

Volume	14.00–14.80 cm <sup>3</sup> (0.85–0.90 cu.in)
Warpage limit*	0.10 mm (0.0039 in)

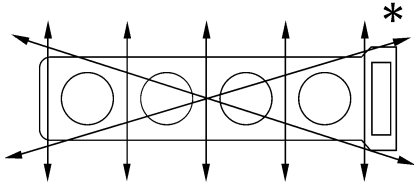

## Camshaft

Drive system	Chain drive (right)
Camshaft cap inside diameter	24.500–24.521 mm (0.9646–0.9654 in)
Camshaft journal diameter	24.459–24.472 mm (0.9630–0.9635 in)
Camshaft-journal-to-camshaft-cap clearance	0.028–0.062 mm (0.0011–0.0024 in)

## Camshaft lobe dimensions

Intake A	34.450–34.550 mm (1.3563–1.3602 in)
Limit	34.350 mm (1.3524 in)
Intake B	25.170–25.270 mm (0.9909–0.9949 in)
Limit	25.070 mm (0.9870 in)
Exhaust A	33.550–33.650 mm (1.3209–1.3248 in)
Limit	33.450 mm (1.3169 in)
Exhaust B	25.192–25.292 mm (0.9918–0.9957 in)
Limit	25.092 mm (0.9879 in)

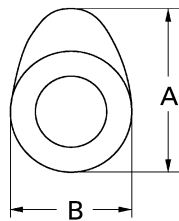

Camshaft runout limit

0.030 mm (0.0012 in)

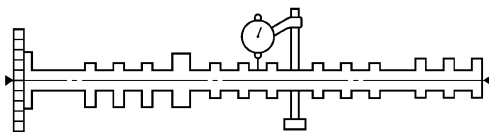

## Timing chain

Model/number of links	RH2020/124
Tensioning system	Automatic

## Valve clearance (cold)

Intake	0.11–0.20 mm (0.0043–0.0079 in)
Exhaust	0.26–0.30 mm (0.0102–0.0118 in)

## Valve dimensions

Valve head diameter A (intake)	30.90–31.10 mm (1.2165–1.2244 in)
Valve head diameter A (exhaust)	24.90–25.10 mm (0.9803–0.9882 in)

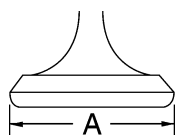

# ENGINE SPECIFICATIONS

Valve face width B (intake)	1.200–2.480 mm (0.0472–0.0976 in)
Valve face width B (exhaust)	1.625–2.900 mm (0.0640–0.1142 in)

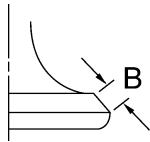

Valve seat width C (intake)	0.90–1.10 mm (0.0354–0.0433 in)
Valve seat width C (exhaust)	0.90–1.10 mm (0.0354–0.0433 in)

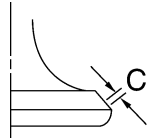

Valve margin thickness D (intake)	1.10–1.50 mm (0.0433–0.0591 in)
Valve margin thickness D (exhaust)	0.50–0.90 mm (0.0197–0.0354 in)

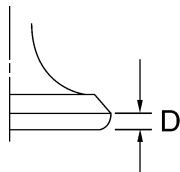

Valve stem diameter (intake)	4.975–4.990 mm (0.1959–0.1965 in)
Limit	4.960 mm (0.1953 in)
Valve stem diameter (exhaust)	4.460–4.475 mm (0.1756–0.1762 in)
Limit	4.425 mm (0.1742 in)
Valve guide inside diameter (intake)	5.000–5.012 mm (0.1969–0.1973 in)
Limit	5.050 mm (0.1988 in)
Valve guide inside diameter (exhaust)	4.500–4.512 mm (0.1772–0.1776 in)
Limit	4.550 mm (0.1791 in)
Valve-stem-to-valve-guide clearance (intake)	0.010–0.037 mm (0.0004–0.0015 in)
Limit	0.080 mm (0.0032 in)
Valve-stem-to-valve-guide clearance (exhaust)	0.025–0.052 mm (0.0010–0.0020 in)
Limit	0.100 mm (0.0039 in)
Valve stem runout	0.010 mm (0.0004 in)

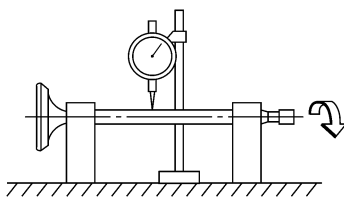

Cylinder head valve seat width (intake)	0.90–1.10 mm (0.0354–0.0433 in)
Cylinder head valve seat width (exhaust)	0.90–1.10 mm (0.0354–0.0433 in)

# ENGINE SPECIFICATIONS

## Valve spring

Inner spring	
Free length (intake)	39.79 mm (1.57 in)
Free length (exhaust)	38.42 mm (1.51 in)
Installed length (intake)	35.50 mm (1.40 in)
Installed length (exhaust)	33.00 mm (1.30 in)
Spring rate K1 (intake)	42.91 N/mm (245.02 lb/in) (4.38 kgf/mm)
Spring rate K2 (intake)	56.23 N/mm (321.07 lb/in) (5.73 kgf/mm)
Spring rate K1 (exhaust)	40.10 N/mm (228.97 lb/in) (4.09 kgf/mm)
Spring rate K2 (exhaust)	51.85 N/mm (296.06 lb/in) (5.29 kgf/mm)
Installed compression spring force (intake)	171–197 N (38.44–44.29 lbf) (17.44–20.09 kgf) at 35.50 mm (1.398 in)
Installed compression spring force (exhaust)	202–232 N (45.41–52.15 lbf) (20.60–23.66 kgf) at 33.00 mm (1.299 in)
Spring tilt (intake)*	2.5 °/1.7 mm
Spring tilt (exhaust)*	2.5 °/1.7 mm

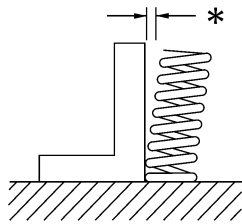

Winding direction (intake)	Clockwise
Winding direction (exhaust)	Clockwise

## Cylinder

Bore	77.000–77.010 mm (3.0315–3.0319 in)
Taper limit	0.050 mm (0.0020 in)
Out of round limit	0.050 mm (0.0020 in)

## Piston

Piston-to-cylinder clearance	0.010–0.035 mm (0.0004–0.0014 in)
Limit	0.12 mm (0.0047 in)
Diameter D	76.975–76.990 mm (3.0305–3.0311 in)
Height H	12.0 mm (0.47 in)

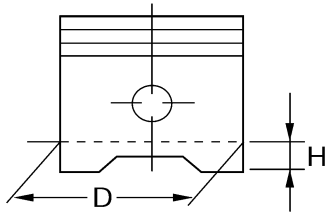

Offset	0.50 mm (0.0197 in)
Offset direction	Intake side
Piston pin bore inside diameter	17.002–17.013 mm (0.6694–0.6698 in)
Piston pin outside diameter	16.991–17.000 mm (0.6689–0.6693 in)

## Piston ring

Top ring	
Ring type	Barrel
Dimensions (B × T)	0.90 × 2.75 mm (0.04 × 0.11 in)



# ENGINE SPECIFICATIONS

End gap (installed)	0.15–0.25 mm (0.0059–0.0098 in)
Ring side clearance	0.030–0.065 mm (0.0012–0.0026 in)
2nd ring	
Ring type	Taper
Dimensions (B × T)	0.80 × 2.75 mm (0.03 × 0.11 in)

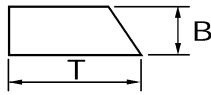

End gap (installed)	0.30–0.45 mm (0.0118–0.0177 in)
Ring side clearance	0.020–0.055 mm (0.0008–0.0022 in)
Oil ring	
Dimensions (B × T)	1.50 × 2.25 mm (0.06 × 0.09 in)

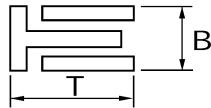

End gap (installed)	0.10–0.40 mm (0.0039–0.0157 in)
---------------------	---------------------------------

## Connecting rod

Oil clearance (using plastigauge®)	0.034–0.058 mm (0.0013–0.0023 in)
Bearing color code	1.Blue 2.Black 3.Brown 4.Green

## Crankshaft

Width A	55.20–56.60 mm (2.173–2.228 in)
Width B	298.75–300.65 mm (11.76–11.84 in)
Runout limit C	0.030 mm (0.0012 in)
Big end side clearance D	0.160–0.262 mm (0.0063–0.0103 in)

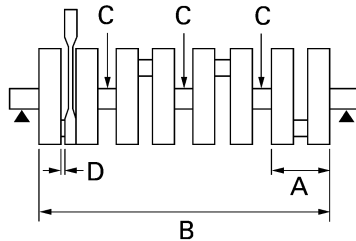

Journal oil clearance (using plastigauge®)	0.014–0.037 mm (0.0006–0.0015 in)
Bearing color code	0.White 1.Blue 2.Black 3.Brown 4.Green

## Clutch

Clutch type	Wet, multiple-disc
Clutch release method	Outer pull, rack and pinion pull
Clutch lever free play	10.0–15.0 mm (0.39–0.59 in)
Friction plate thickness	2.90–3.10 mm (0.114–0.122 in)
Wear limit	2.80 mm (0.1102 in)
Plate quantity	9 pcs
Clutch plate thickness	1.90–2.10 mm (0.075–0.083 in)
Plate quantity	8 pcs
Warpage limit	0.10 mm (0.0039 in)
Clutch spring free length	43.80 mm (1.72 in)
Spring quantity	6 pcs

## Transmission

Transmission type	Constant mesh 6-speed
Primary reduction system	Spur gear
Primary reduction ratio	65/43 (1.512)
Secondary reduction system	Chain drive